

iGEM 2015

Judging Handbook: Part 1

A Guide to Judging at the iGEM Jamboree

Ana - links are displayed like this: {text for link} [link]. Thanks!

iGEM Executive Judging Committee

Table of Contents

[Introduction from the Executive Judging Committee](#)

[Projects](#)

[Case Study 1: Heidelberg 2014](#)

[Case Study 2: UC Davis 2014](#)

[Case Study 3: Paris-Bettencourt 2013](#)

[Case Study 4: Calgary 2012](#)

[Medals](#)

[Standard Pages and static links](#)

[Judging Forms](#)

[Bronze](#)

[Silver](#)

[Gold:](#)

[Standard Pages for Special Prizes:](#)

[Awards with no required standard page:](#)

[Special Prizes](#)

[Human Practices](#)

[Integrated Human Practices](#)

[Education and Public Engagement](#)

[Measurement Approach](#)

[Models](#)

[Presentations](#)

[Wikis](#)

[Basic and Composite Parts](#)

[Entrepreneurship](#)

[Case Study 1: Benchling](#)

[Judging analysis](#)

[Case study 2: Darwin Toolbox:](#)

[Case Study 3: FREDsense](#)

[Applied Design](#)

[Posters](#)

[Expected iGEM Poster Components](#)

[Poster Evaluation Criteria](#)

[Poster Judging Process](#)

[Software Tool](#)

[New Tracks](#)

[Art & Design](#)

[Community Labs](#)

[Hardware](#)

[High School](#)

[High School Case Study 1: Lethbridge 2013](#)

[Measurement](#)

[Software](#)

[Acknowledgements](#)

Introduction from the Executive Judging Committee

Additional info to include in 2015:

-

Welcome to iGEM and thank you for volunteering to judge our competition. 2014 is a big year for iGEM. To celebrate our 10th anniversary, we are hosting our first Giant Jamboree, our biggest Jamboree so far, and the biggest synbio event worldwide to date. We have 226 teams and over 2000 registered attendees, all of whom are coming to Boston to present their work.

We have worked hard to make judging better in 2014. For example, we have a new handbook to help you learn how to evaluate teams. We have also created a Responsible Conduct Committee (RCC) to address team or judge behavior complaints. Because this is the largest Jamboree we've ever had, we have more judges than ever before. With the help of software, we are making it easier to evaluate medals. Finally, we have new types of judges, each with a specific focus and expertise.

Judging in iGEM is complex and it can be hard to learn how to evaluate teams. We are addressing this problem by issuing the judging handbook in two parts. Our brand new first part is filled with case studies of great teams, winning teams, and examples of how iGEM rewards excellence. The judging committee has created a document with some examples of iGEM excellence, and how those projects won their respective awards. While there are certainly other examples of excellence in iGEM, these are our favorite.

We have created the RCC to address cases of integrity, sportsmanship, honesty, respect, or judging violations in iGEM. Complaints can be reported to the RCC by anyone with a concern and a case will be opened. This committee exists for serious violations of the principles of iGEM and should be treated accordingly.

The Giant Jamboree is the largest event in the history of iGEM and also the history of synthetic biology. We have over one hundred judges to ensure teams are fairly and comprehensively evaluated. Because of the sheer number of people to manage at our event, we need judges to ensure they can complete their wiki evaluation assignments ahead of the event. We will also provide a forum for you to ask questions ahead of the event. There will be more open time at this Jamboree, but less time for individual discussions. We are relying on you to understand what you need to accomplish before coming to Boston.

The rubric has been improved this year to make judging medals easier. We will be working on this down to the wire, so expect more on the mechanics of how to perform your judging assignment in part 2 of the handbook.

Finally, There is a lot of excellence in iGEM. We can't possibly show you case studies of all the best projects in iGEM, as there is too much content. We have had over a thousand iGEM teams in our ten-year history. But one element of the competition has always remained the same: we seek to *reward and celebrate excellence* across all areas of iGEM.

Kim de Mora – Judging Coordinator

Pete Carr – Director of Judging

Beth Beason – Executive Judging Committee

Janie Brennan – Executive Judging Committee

Terry Johnson – Executive Judging Committee

How to begin your judging assignment

Teams are competing for 4 main prize categories in the iGEM competition:

- Medals
- Track prize
- Special Prizes
- Grand prize

The first thing you should do is to evaluate the team's medal. Teams can win bronze, silver or gold, depending on how many of the criteria they have fulfilled. Medal criteria increase in difficulty and teams must complete all bronze and silver criteria to be eligible for those medals, while they only need to fulfill two to be eligible for a gold medal. Teams must now convince judges they have met the criteria, instead of merely ticking a box. If a team has stated they have met a criterion and you feel they have not achieved enough to warrant the medal, you can choose to not award them the medal in question.

When you begin your assignment, you will navigate to the team judging form and rubric. The mechanics of how to perform your judging assignment using our online system will be described in the 2nd part of the judging handbook later in the year, so we will not go into detail in this section.

Once you have determined which medal you have decided to award the team, you can move on to evaluating the rubric for the team. The project section will determine where the team will rank in their track and how they will stack up compared to all other teams in the competition.

After evaluating the project section, any other open sections in the rubric will identify which awards the team is competing for. In most cases, the award will directly link to a page on the team wiki with information about what the team have achieved to warrant winning that award. This mechanism is intended to make the lives of judges much easier.

Finally, the highest ranking teams by the project section will become finalists and present during the award ceremony. The last act of being a judge at iGEM is to vote on which team will win the coveted BioBrick trophy.

Projects

What are the characteristics of the *very best* iGEM projects? What sets them apart?

A team that will win the iGEM Competition not only presents a successful and well-communicated project, but also embodies the goals and values of the iGEM Foundation itself – advancement of synthetic biology, impact, education, accomplishment, use of standard parts, and integration of policy and practices, to name a few.

A successful iGEM project includes the following components: a wiki, a poster, a presentation at the Jamboree, and, depending on the track, some sort of deliverable to be used by the community (e.g., DNA parts, software, an art installation, etc). Although great teams demonstrate excellence in all of these components, the *very best* teams go *above and beyond*, not only presenting a clear and powerful story, but also connecting their projects to the wider world through careful consideration of their project’s consequences. Finally, it is important to note that iGEM is about *education*; projects should be motivated, researched, and carried out primarily *by students*. Effective use of available resources is important, but careful attention should be paid to attribution of each part of the project.

These facets of success are reflected in the “Project” section of the rubric, which is one of the main determinants for choosing finalists:

- 1. How impressive is this project?**
- 2. How creative or novel is the team’s project?**
- 3. Did the project work?**
- 4. How much did the team accomplish?**
- 5. Is the project likely to have an impact?**
- 6. How well are engineering and design principles used?**
- 7. How thoughtful and thorough was the team’s consideration of human practices?**
- 8. How complete is the team's effort to attribute work?**

These aspects are the key iGEM values that apply to all teams, irrespective of track. In 2014 track-specific evaluation aspects were introduced to help assess new track teams. These aspects were introduced to reflect the changing nature of the competition and that not all new track teams are required to evaluate parts - a key part of all iGEM teams until 2014.

Winning teams don’t necessarily need to score highly in every aspect; they create work that impresses the judges. Impressing the judges is what distinguishes winning teams from great teams. Using the rubric, judges can reward the best work according to how impressive it is, instead of according to a minimum set of criteria that teams need to meet. This difference is

significant, as the scale and scope of work is not limited to “tick box” criteria that teams need to achieve, but by how much they can achieve in a given time.

To get a better idea of what judges recognize as exemplary, we will explore four projects: {Heidelberg 2014} [<http://2014.igem.org/Team:Heidelberg>], UC-Davis 2014, {[Paris Bettencourt 2013](http://2012.igem.org/Team:Calgary)} [<http://2012.igem.org/Team:Calgary>] and {[Calgary 2012](http://2012.igem.org/Team:Calgary)} [<http://2012.igem.org/Team:Calgary>].

[://2012.igem.org/Team:Calgary](http://2012.igem.org/Team:Calgary)

Case Study 1: Heidelberg 2014

[<http://2014.igem.org/Team:Heidelberg>]

Heidelberg chose to develop synthetic biology approaches for circularizing proteins, aiming to make those proteins more heat- and pH-stable, and resistant to proteases. As proofs of principle, they offer data on the heat stability of lysozyme, of the xylanase enzyme from *B. subtilis* (chosen for its relevance to industry, and for its potential high-temperature applications), and of a methyltransferase (to potentially maintain methylation patterns during PCR cycles).

Their project makes use of {[inteins](http://en.wikipedia.org/wiki/Intein)} [<http://en.wikipedia.org/wiki/Intein>], which mediate post-translational protein splicing. On their wiki, they show the general mechanism (left) along with the team’s circularization method for a protein of interest (POI) (right):

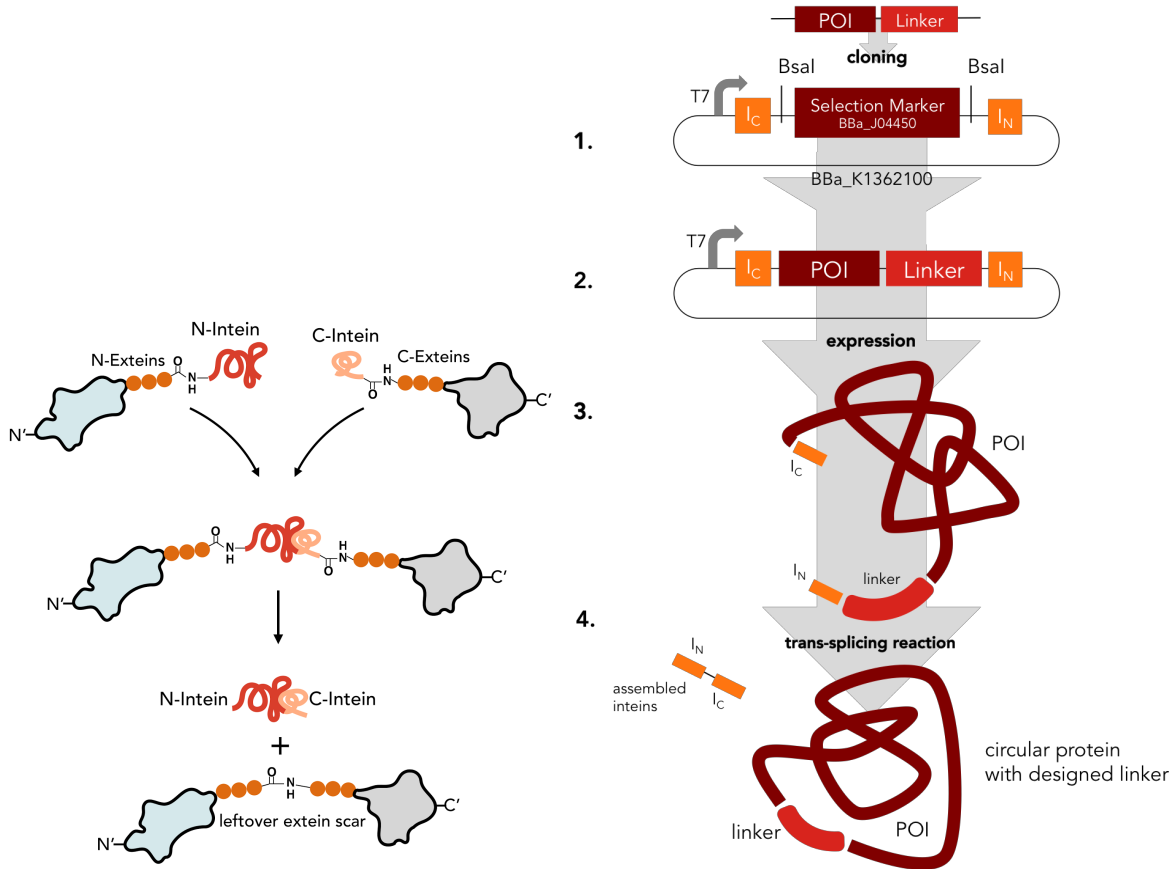

The design of the linker could be critical, as the students suggested that a flexible linker would be unlikely to add much to the proteins stability. They created [software](http://en.wikipedia.org/wiki/Intein) [http://en.wikipedia.org/wiki/Intein] to design rigid linkers appropriate to the protein when the C- and N-termini of a protein were not close together, and made this software [available to the community, with appropriate documentation](#). They also tested this design scheme with lysozyme that had been circularized with a flexible linker vs. software-designed rigid linkers. The images that follow are from their final presentation at the jamboree.

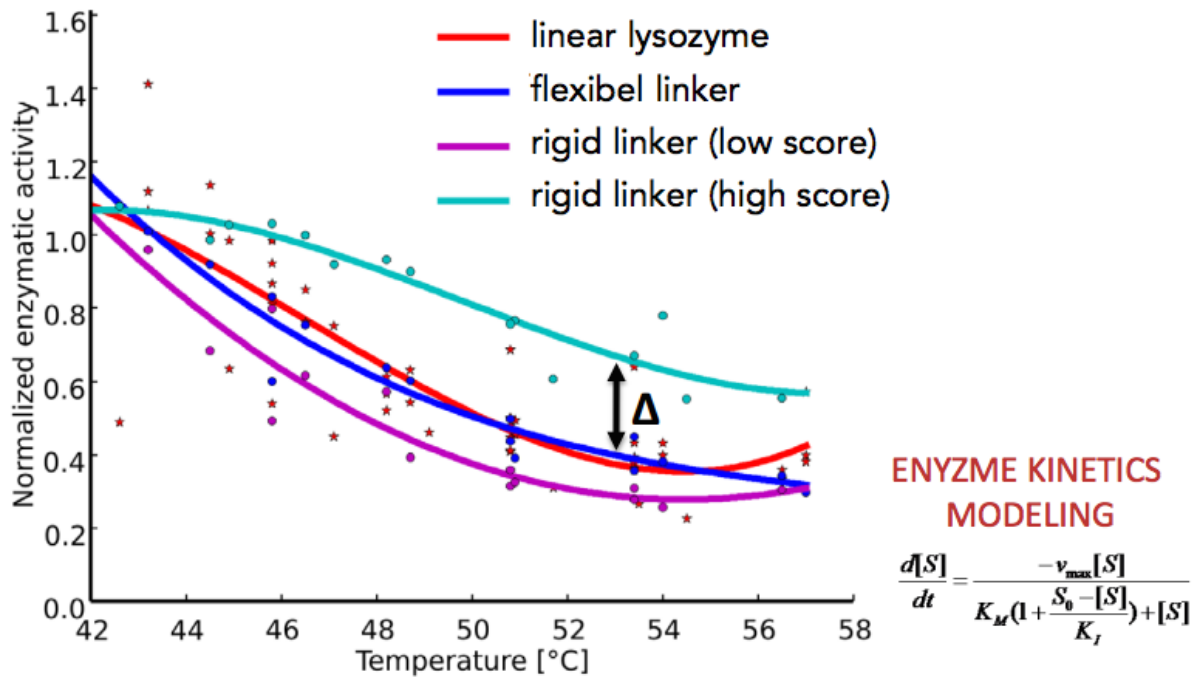

The rigidly linked lysozyme had better heat stability than the linear or flexibly linked lysozyme (though they had different baseline activities at 42C).

Likewise, their circularized xylanase maintained appreciable activity at 63C compared to the linear version, which had practically no activity.

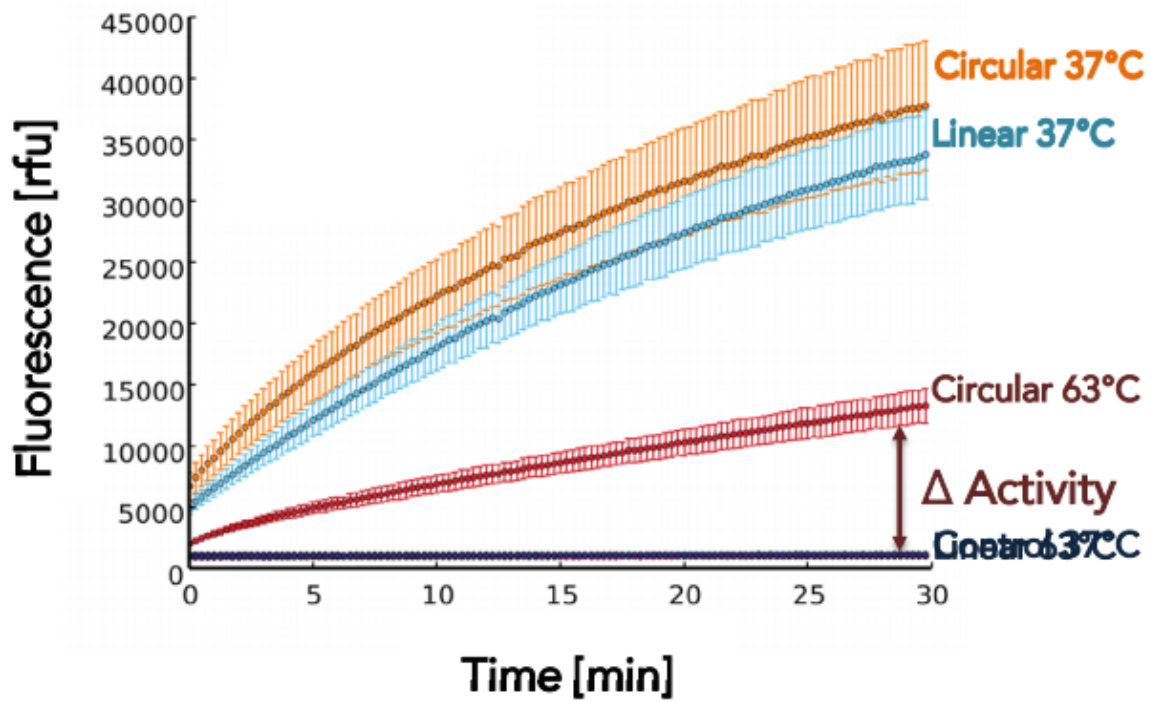

Finally, the heat stability of a circularized methyltransferase.

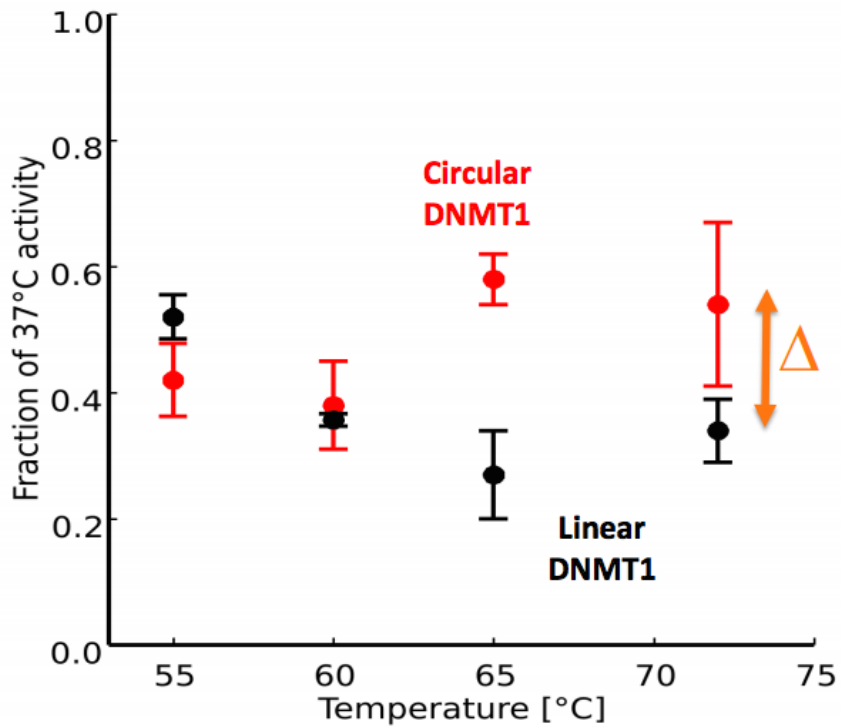

In judging Heidelberg 2014, I would emphasize the following. The project is **impressive**, delivering parts that can be applied to a variety of situations where protein stability is a factor. The project is **novel** within iGEM (inteins have shown up at iGEM before, but not for this application - I searched “inteins” on the parts registry to get a flavor for what has been done before). The team provides compelling evidence that the project **works**, and in a variety of contexts, which is a significant **accomplishment** - many teams demonstrate proof of principle in a single context only, and few as well and as quantitatively as seen here.

Regarding the **design** of the circularization system: the team has considered not only the biobricks, but the three-dimensional structure of the protein and the appropriate properties of the linker. Their kinetic models are very standard stuff, but their model for linker design is new, and by making it available online, the team makes it more likely that this generalized system for improving protein stability will have an **impact** through its use by future iGEM teams. This consideration for their circularization system’s potential users is an example of **human practices** - their users are other synthetic biologists, and they’ve made efforts to make the system usable to those in the community. (*Judge comment*: “Really great to see clean development of tools that make research easier for others: CRAUT, iGEM@home, thermostable DNMT1.”)

Case Study 2: UC Davis 2014

After learning that over 70% of imported olive oils and many US olive oils are rancid, UC Davis chose to develop a method to help ensure consumers receive quality extra virgin olive oil. Their “OliView” project consisted of these major components: 1) protein engineering; 2) electrochemistry; 3) potentiostat development; and 4) signal processing. The development of an enzyme based electrochemical biosensor for the evaluation of rancidity in olive oil is nicely summarized in the “How Did We Do It?” diagram:

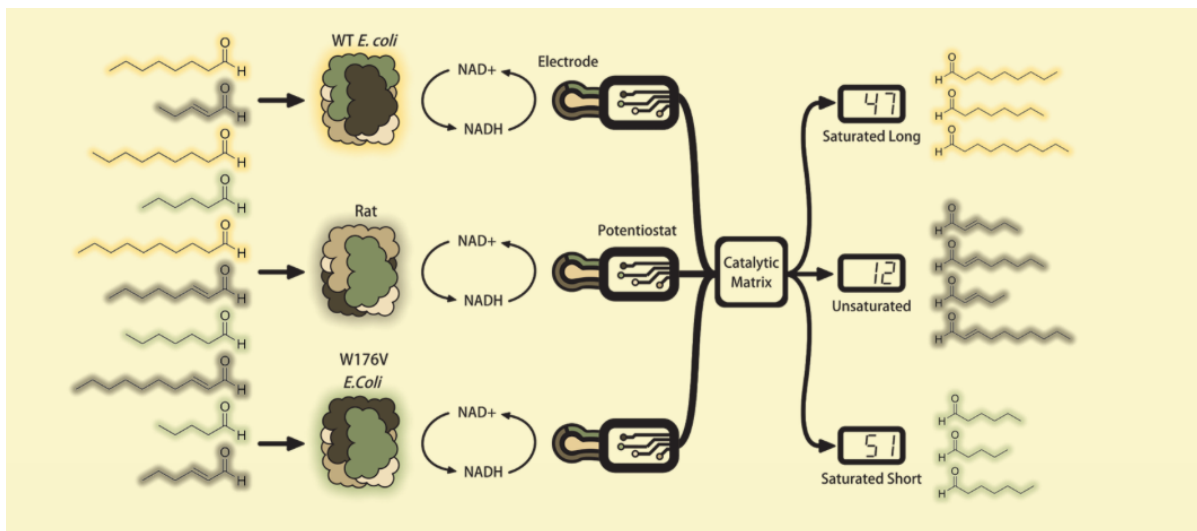

Let's look at specific aspects nicely addressed by their project.

How much did the team accomplish? Did the project work?

First, they identified NAD⁺ dependent aldehyde dehydrogenases with unique specificity profiles from online databases and designed 20 mutants of *E. coli* aldehyde dehydrogenase. They developed a simple spectrophotometric plate assay which measured the concentration of NADH in a solution. Using this assay, they screened 23 aldehyde dehydrogenases against all sixteen aldehyde substrates they previously identified to occur in olive oil. They identified three enzymes with unique specificity profiles:

Average Catalytic Efficiency

	Medium, saturated Aldehydes (C5-C7)	Long, saturated Aldehydes (C8-C10)	Unsaturated Aldehydes
WT <i>E. coli</i> ALDH BBa_K1324000	100%	95%	8%
W176Q Mutant <i>E. coli</i> ALDH BBa_K1324001	98%	100%	2%
WT Rat ALDH BBa_K1324003	100%	75%	71%

They needed to develop an electrode system to detect enzyme activity via NADH. To accomplish this part of their project, they acquired, selected, and optimized an electrode setup for the detection of NADH at low concentrations in a complex solution. Additionally, they built and tested a potentiostat to measure enzyme-generated NADH (see *Case Study in the Hardware section*).

Enzyme-generated NADH can be detected

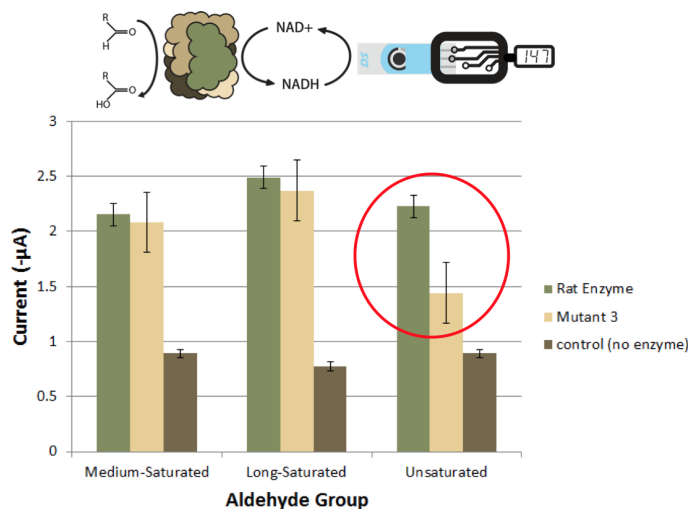

UCDAVIS

iGEM 2014

After validating that their system could detect enzyme activity, they developed a mathematics and software suite to connect measured aldehyde profiles to the degree of

rancidity in a particular olive oil. They tested their working model with nine samples of extra virgin olive oil. They successfully detected two out of three rancid samples.

Olive Oil Predictions

(μM)

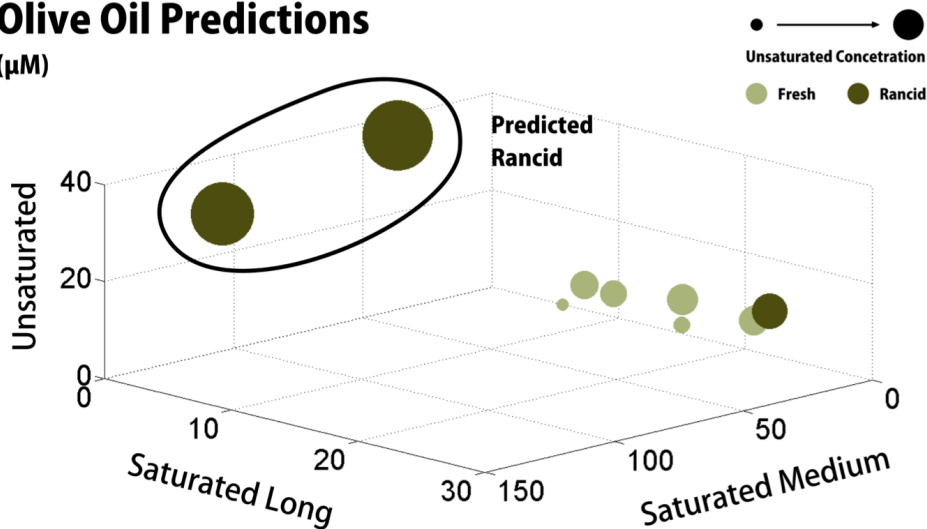

How thoughtful and thorough was the team's consideration of human practices?

To satisfy the gold medal requirement, UC Davis conducted an in depth analysis of how customers and stakeholders in the olive oil industry influenced their project and how their project could possibly impact them. Here's the title page from their whitepaper:

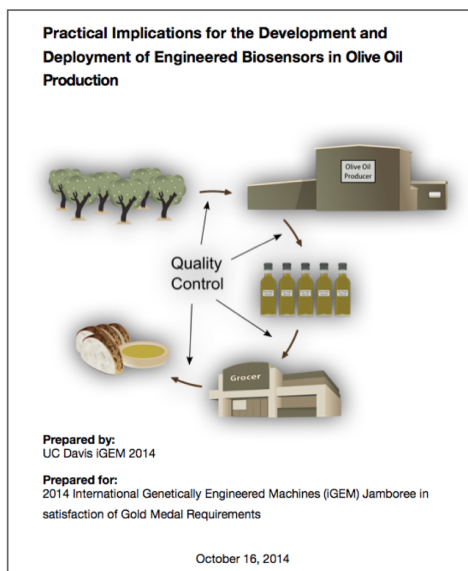

Throughout the summer, the team met with representatives from the largest producers of extra virgin olive oil in California. They toured production facilities and learned about industry quality control. Inspired by discussions about producer interest in new analytical devices, they chose to build a new device to detect aldehydes in rancid olive oil. After participating in several olive oil tastings, they decided to reach out to the community by holding their own olive tasting to educate consumers about how rancid olive oil tastes as compared to fresh olive oil. And they attended a public hearing organized by the California Department of Food and Agriculture at the State Capitol to record evidence and testimony presented by olive growers, millers, and the general public on a set of standards proposed by the Olive Oil Commission California (OOC). Human Practices was deeply integrated with the team's project and substantially addressed broader concerns.

UC Davis won Best Policy & Practices Advance, Overgrad section. Here's what the judges had to say:

"...The Policy and Practices is completely integrated with the project and the motivation and driving force for OliView..."

"...You clearly integrated your policy and practices into the overall project. The end-to-end work from science to technology development was especially impressive..."

"...All of their work pointed to the central question of the tier project. They explored the market, the legislation and the science of the rancid olive oil. Their report demonstrates a superior depth of thought and analysis."

How impressive is this project?

UC Davis was the Grand Prize Winner, Overgrad section at the iGEM 2014 Giant Jamboree. The judges were impressed with how the project was designed and executed. The motivation for and potential applications of the project were clearly defined. Engineering principles were professionally incorporated into the project. And the project was clearly communicated to a wide audience on the team wiki and poster and in the presentation. This comment from one of the judges describes their accomplishments very nicely: "Your team is a top-notch example of a successful iGEM team and project...Not only have you succeeded in obtaining a 360 degree view of the labeling and testing standard of olive oil produced in California, you have effectively used engineering and design principles to produce a device that is convincingly functional, and promises to have a big impact on the field..."

Case Study 3: Paris-Bettencourt 2013

[http://2013.igem.org/Team:Paris_Bettencourt]

The 2013 grand prize winner Paris Bettencourt chose to tackle the worldwide problem of Tuberculosis (TB). In doing so, they took a holistic approach, seeking to eradicate TB through – not just one or two, but *four* – strikingly different strategies (see figure below):

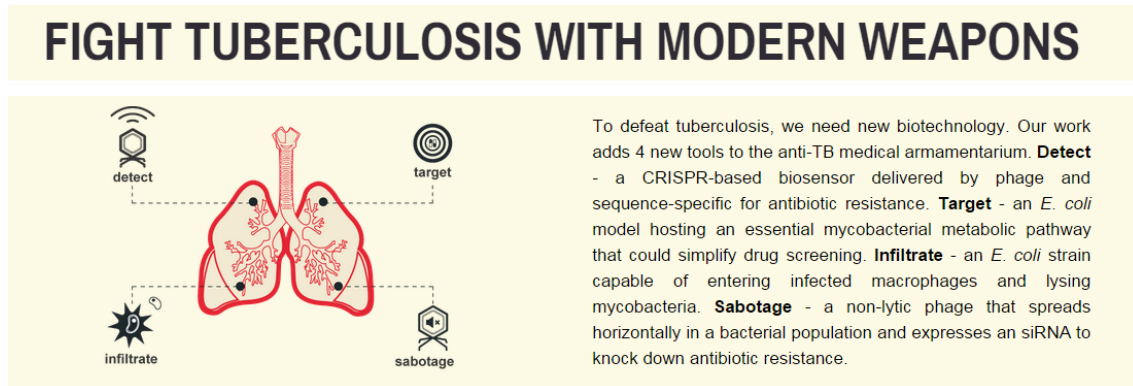

The project spanned a wide range of techniques – from traditional engineering of *E. coli* to CRISPR to phage systems to combinatorial drug screening. From this alone, we can tell that the team has done their research into TB; they seem to grasp the complexities of the situation and have decided that a multi-pronged approach is necessary. Aside from anything else, the creativity (rubric aspect **2**) and ambition shown here is impressive (aspect **1**).

What is more impressive is that this project *worked*, and it did so on many levels (aspect **3**). Let's look at two of their strategies: "Target" and "Sabotage".

For "[Target](#)", the team designed a creative method for drug screening based on the sulfite reduction pathway (see figures below), part of the metabolism that is critical for TB function. They began by modeling the effects of this drug screening design on *E. coli*, and also created a script to identify potential metabolic targets for drugs that could be applied to other diseases. In doing so, they demonstrate excellent use of engineering and design principles (aspect **6**), since their design is easily applied to other situations. The team then picked a target protein and found pyridoxine and riboflavin to be potential drug targets through extensive modeling. After cloning in their mycobacterial sulfite reduction pathway into *E. coli*, they found that pyridoxine would affect the mycobacterial pathway (and not the wild type *E. coli* pathway) at high doses. Working with the NIH, they received two drug libraries and screened them with their assay. They found ten potential drug candidates, several of which have structural similarities to pyridoxine. Not only did their targeting system

work (aspect 3), but it is likely to have an impact (aspect 5), since no novel drugs have been found for TB in several decades.

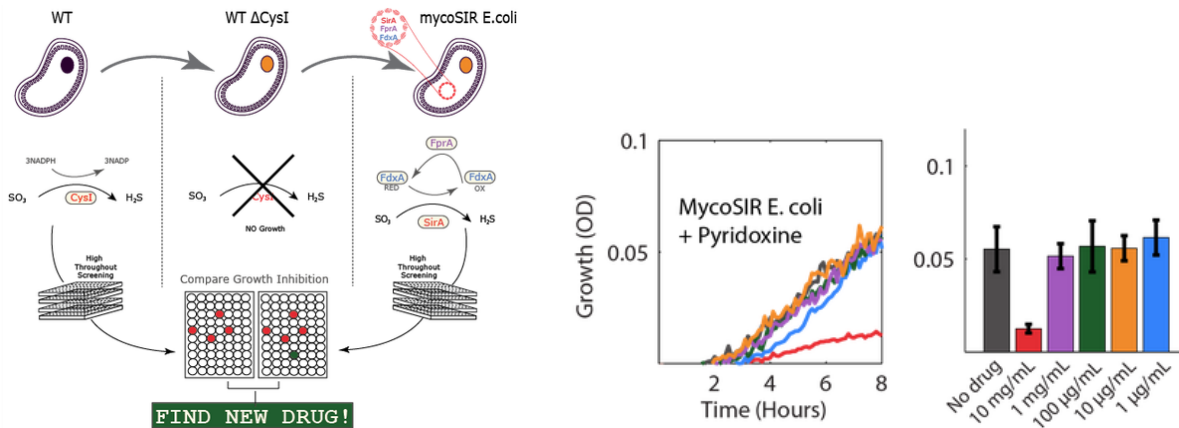

Looking instead at the “Sabotage” strategy, Paris Bettencourt focused on taking down TB possessing multiple antibiotic resistances, as multiple antibiotic resistance is a significant problem for multiple disease types. They designed a low-burden phage delivery system for siRNA that would essentially knock out the antibiotic resistances of TB, keeping in mind and modeling possible effects of metabolic burden from their system (aspect 6). After applying their system, they efficiently killed over 99% of an antibiotic resistance-containing bacterial population (both chloramphenicol and kanamycin), demonstrating that their system worked (aspect 3). Taking their system further, they analyzed how any remaining bacteria were able to survive. The team determined that 70% of resistance to their knockout system resulted from a resistance to the siRNA itself. Even if their system is not entirely viable for clinical use, their system is designed such that a single PCR reaction can switch out the gene target for any target of interest, and could therefore be of great use to future iGEM teams (aspect 5).

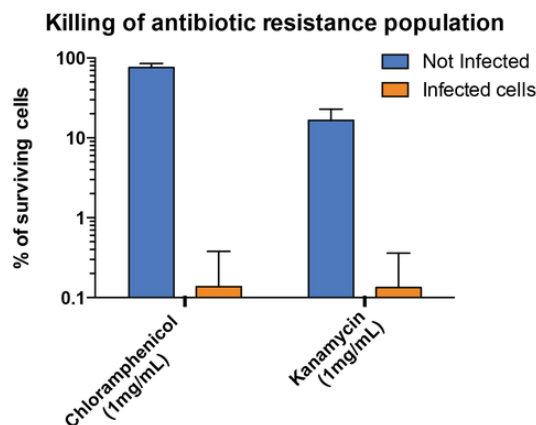

The 2013 Paris Bettencourt team was wildly successful on many fronts. The facets described here are only a brief look into the quality

and breadth of the total project. Other notable features include a collaboration to report [sensor development in iGEM](#) and a [study of gender equality](#) in synthetic biology, which is even now influencing the organization and leadership within iGEM. Above everything, however, we should keep in mind that Paris Bettencourt *impressed the judges* (aspect **1**). They did this through their creativity (**2**), the successful function of their well-designed systems (**3, 6**), the extent of their accomplishments (**4**), and the potential impact (**5**) of their work. Their project exemplifies the ideals and goals of iGEM.

Case Study 4: Calgary 2012

[<http://2012.igem.org/Team:Calgary>]

The team focused on bioremediation of tailing ponds, which are large bodies of water that accumulate toxic compounds as a byproduct of the oil extraction process in the oil sands of northern Alberta. They worked on two creative (**aspect 2**) projects, **FRED** and **OSCAR** (see figures below):

FRED

FRED stands for the **F**unctional, **R**obust **E**lectrochemical **D**etector, and he is one of our mascots for the 2012 iGEM Calgary project.

FRED is involved in creating a biosensor that will work in environments where traditional biosensors will not, such as in turbid or anaerobic environments. This is important for oil sands applications such as in the tailings ponds where detection of toxins is needed but where the environments are murky and any samples taken from below a meter depth are low in oxygen. While there are traditional methods for detection of toxins, such as gas chromatography-mass spectrometry (GC-MS) or fourier transform infrared spectroscopy (FTIR), these techniques involve expensive machinery, skilled technicians, transport offsite and pre-processing before any data can be obtained. FRED will be able to do onsite testing in a matter of minutes with no advanced training required for users.

Functional,
Robust
Electrochemical
Detector

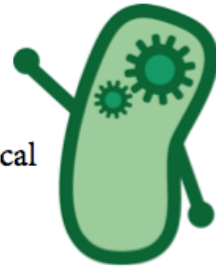

OSCAR

The **O**ptimized **S**ystem for **C**arboxylic **A**cid **R**emediation, or OSCAR, is the **D**estroy component to our iGEM 2012 Calgary project. With our detection system in place, OSCAR converts toxic compounds, such as naphthenic acids and catechol, into hydrocarbons by removing unwanted carboxylic acid and hydroxyl groups.

By conversion to hydrocarbons we can not only detoxify tailing waters but provide an economically viable method for doing so. By using flux balance analysis we developed a system to optimize the output of carboxylic acid removal system which we validated in the wetlab. Furthermore we developed a bioreactor prototype to demonstrate the applicability of our system using novel hydrocarbon collection methodologies. Finally, we developed constructs and genetic circuits to upgrade these hydrocarbons to reduce sulfur and nitrogen content. Altogether, OSCAR provides a method to upgrade naphthenic acids and other toxic components from waste products into useable fuels.



Optimized
System for
Carboxylic
Acid
Remediation

FRED involved creating a biosensor to work in turbid or anaerobic environments; this novel biosensor has potential to be of great value to the iGEM community as it will work in environments where traditional biosensors will not. The team accomplished a great deal (**aspect 4**) as evidenced by the number and type of parts that were submitted to the registry (see [Calgary 2012 Parts](#)). On the [Detect and Destroy: Data Page](#), they show how the dual system works (see figure below) and summarize the parts they submitted or further characterized.

Detect and Destroy: Data Page

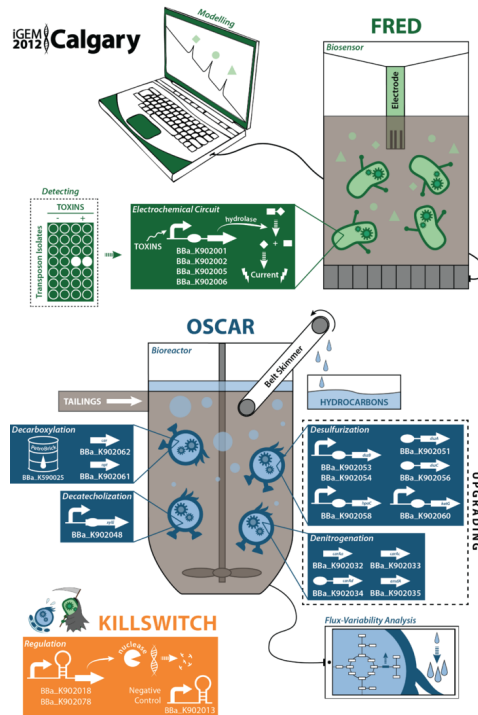

It's clear from Calgary's [team members](#) and [attributions](#) pages that they did the project themselves (**aspect 8**). They indicate which team members worked on which facets of the project and also describe additional support they received both inside and outside their home university. Additionally, this information is easy to find on their wiki.

The team's consideration of human practices (**aspect 7**) was "deeply integrated with the team's project and substantially addressed a broader concern." [Calgary's human practices component](#) drove the design of their project and provides an outstanding example for other teams. They participated in a dialogue about synthetic biology with the Oil Sands Leadership Initiative (OSLI) and conducted extensive interviews with leaders in oil sands reclamation in the early stages of project development as well as follow-up interviews with other experts to determine whether they had successfully addressed concerns from the first set of interviews.

And they designed multiple layers of controls for FRED and OSCAR, including both physical (e.g., closed systems) and biological (an inducible ribo-killswitch system), to minimize the chance of releasing them into the environment.

Calgary clearly *impressed the judges* (**aspect 1**). At the Americas West Regional Jamboree in 2012, they were a regional finalist and were awarded Best Wiki, Best Poster, Best Model, Best Human Practices Advance, and a Safety Commendation. At the World Championship Jamboree, they also won Best Human Practices Advance. Aside from being impressive, the Calgary 2012 team was worthy of commendation, as their project was done *by students* (**aspect 8**), was creative (**2**), accomplished a great deal (**4**), and thoughtfully and thoroughly considered human practices (**7**).

Medals

Finalists demonstrate the very best work in a given year in the iGEM competition, but all teams are competing for medals. The number of medals is not limited and teams are only competing with themselves to meet the criteria. Teams can be awarded no medal, bronze, silver or gold. For a bronze, teams must meet all 6 criteria. For Silver, teams must meet the 3 medal criteria. For a gold medal however, teams must meet at least 2 of the 4 available criteria. Once the team's medal has been determined, judges are advised to move one to the other parts of the rubric.

Standard Pages and static links

To make it easier for judges to find relevant documentation, we have created standard pages with static (unchangeable) links for all awards and for most medal criteria. If a team wants to be evaluated for an award/medal, they will need to document their achievements related to the award/medal on a standard page. For example, if a team wants to be evaluated for the Parts Collection prize, they must document your work on:

[http://2015.igem.org/Team:\[NAME\]/Part_Collection](http://2015.igem.org/Team:[NAME]/Part_Collection).

They must also complete the 150 word description of their achievements, or judge are not required to evaluate that award.

Judges will be directed to these pages from static links within the judging form. Teams should not change the location or URL of these pages in their wiki. *If documentation for an award is not on the page encoded by the static link, the team may not be eligible to be judged for that prize.*

Why the change? In 2014, teams were required to enter their own page links into the judging form to be evaluated for some awards. Sometimes these links did not work. For example, some teams used web design packages that created dynamic links, and the system could not identify these pages.

Since specific pages on a team wiki can be hard to find, standard pages with static links were created to help judges find the information they need to evaluate specific awards. Teams are not limited to using only these standard pages, but they must be concise with the placement of their content on their wiki.

What does this mean? Regardless of how wikis are styled, teams will need to preserve the designated URLs in order to be evaluated for the awards listed below. Some web design

packages can create dynamic links will not work with this system. Evaluation of awards with incorrect links is at the discretion of the judges.

So where are the links? Team wiki templates were created with all of the necessary pages by default. Teams can refer to the list of pages below, as well. Teams must use their own official team name space. For example: <http://2015.igem.org/Team:Example>.

When striving for an award, note that it is not sufficient for a team to simply fulfill the award criteria. Teams must *convince the judges* that they have satisfactorily fulfilled the criteria. If the judges are not convinced after reading through documentation (on your wiki and on the Registry), they may choose to not award a prize or medal.

Judging Forms

Below are standard links to the team "Example" template pages. For team pages, please replace "Example" with the team name to find the page on the wiki, or navigate to that page using the menu in the team namespace.

Bronze

All criteria must be met:

- Bronze #1 – #4: No special page required.
- Bronze #5 (Attributions): <http://2015.igem.org/Team:Example/Attributions>
- Bronze #6 (Part or Other for New Track teams): <http://2015.igem.org/Team:Example/Parts>. If a part is required, teams will additionally need to provide a part number in the part number range.

Silver

All criteria must be met:

- Silver #1 (Part data): Part number in your part number range is required when filling out the judging form. *Data must be on the Part page on the Registry.*
- Silver #2 (Proof of part submission): Part number MUST be different to Silver #1 submission. Teams will need to provide a part number in their part number range when filling out the judging form.
- Silver #3 (Human Practices): <http://2015.igem.org/Team:Example/Practices>

Gold:

At least **two (2)** criteria must be met:

- Gold #1 (Human Practices): <http://2015.igem.org/Team:Example/Practices>

- o Please note that this page will be automatically completed if the team is going for the silver medal criteria. It is up to the judge to determine if the HP work is of silver and gold quality.
- Gold #2 (Collaboration): <http://2015.igem.org/Team:Example/Collaborations>
- Gold #3 (Improving a previous iGEM project): Include in project description page <http://2015.igem.org/Team:Example/Description>.
- Gold #4 (Functional prototype): <http://2015.igem.org/Team:Example/Design>

Standard Pages for Special Prizes:

- Integrated Human Practices: <http://2015.igem.org/Team:Example/Practices>
- Education and Public Engagement: <http://2015.igem.org/Team:Example/Practices>
- Measurement: <http://2015.igem.org/Team:Example/Measurement>
- Model: <http://2015.igem.org/Team:Example2/Modeling>
- Basic Part: http://2015.igem.org/Team:Example/Basic_Part
- Composite Part: http://2015.igem.org/Team:Example/Composite_Part
- Parts Collection: http://2015.igem.org/Team:Example/Part_Collection
- Software Tool: <http://2015.igem.org/Team:Example/Software>
- Entrepreneurship: <http://2015.igem.org/Team:Example/Entrepreneurship>
- Applied Design: <http://2015.igem.org/Team:Example/Design>

Awards with no required standard page:

- Best Wiki
- Best Poster
- Best Presentation
- Track Awards (based on total body of work, not any specific page)

Special Prizes

Special prizes are awarded to teams in iGEM who excel in focus areas of the competition. All teams are eligible for special prizes and they will be distributed by section. Undergraduate, Overgraduate and High School sections will each receive a prize. All special prizes will be awarded providing that:

1. More than 10 teams are competing for the prize
2. The works is deemed of sufficiently high quality to warrant distributing the award by the judges
3. A high enough number of judges vote for the special prize in question

Human Practices

Human Practices has been an important component of iGEM since 2008 and is a mandatory activity for teams wishing to obtain a Silver or Gold medal, and we expect most teams to complete some HP work. We welcome a wide variety of approaches within HP – teams can pursue questions relating to regulatory, economic, ethical, social, legal, philosophical, ecological, security or other societal questions relating to synthetic biology. Over the last few years, we have seen teams produce some truly outstanding work in the areas of education and public engagement but have not been able to reward these teams because they did not fit within the judging rubric of human practices. So this year we have established two separate prizes within human practices: Best Integrated Human Practices and Best Education and Public Engagement.

This year there will NOT be designated HP judges and ALL judges will be evaluating the human practices components of a team's project. Therefore we have made some changes to the judging rubric in order for all judges to be able to evaluate a team's HP work.

Integrated Human Practices

Best Integrated Human Practices projects involve important questions beyond the bench relating to (but not limited to) ethics, sustainability, social justice, safety, security, environmental impact or intellectual property rights. Judges should evaluate whether a team can demonstrate that they have investigated and addressed one or more of these issues. In addition a team needs to demonstrate that the results of this investigation are fully integrated into the design, execution and presentation of their project. The team should be able to document how their project evolved based on the information acquired from these activities. While methodology is important, it should not necessarily be the focus of the judge's evaluation. Focus on WHY the team has chosen their specific activities, WHAT they have done and accomplished and HOW it has been integrated into the "wet" lab portion of their project.

More specifically, the current iGEM rubric contains four aspects for evaluating Best Integrated Human Practices advance. These questions have been updated from the 2014 Jamboree to incorporate the changes made to the requirements in human practices.

1. Does the team's human practices work represent a novel contribution? (in methods, data or understanding of a topic)
2. How much did the team accomplish through their HP efforts?
3. How well integrated with the broader project was the HP work?
4. Does the HP project provide a good example for others?

Education and Public Engagement

Best Education and Public Engagement projects should involve innovative educational tools and public engagement activities that have the ability to discuss the science behind synthetic biology, spark new scientific curiosity and establish a public dialogue about synthetic biology with and from voices outside the lab. It is NOT about prophesizing how great iGEM is or how synthetic biology can save the world. Projects may not necessarily have anything to do directly with their “wet” lab work. Instead judges should focus their evaluations on whether a dialogue was established between the team and the public. Teams should be able to demonstrate that this dialogue was bi-directional. Teams should be able to demonstrate that they have learned from the interaction and/or that the opportunity for learning was built into the activity. Judges should focus on WHY the team has chosen their specific activities, WHAT they have done and accomplished and HOW they have learned from the activity.

More specifically, the current iGEM rubric contains five aspects for evaluating Best Education and Public Engagement advance. These questions are new to the 2015 Jamboree and ALL judges should evaluate a team’s Education and Public Engagement activities.

1. Did the team demonstrate an innovative educational tool/activity that relates to their project?
2. Was a dialogue established between the team and the public in relation to their project (or synthetic biology in general)?
3. How much did the team accomplish through their HP efforts?
4. Is the activity repeatable/adaptable for other projects?
5. Did the team learn from the interaction with the public?

The P&P committee has provided links to some excellent past projects on the {Practices Hub}[http://2015.igem.org/Practices_Hub] which exemplifies work in both the Best Integrated Human Practices and Best Education and Public Engagement activities. It is important to note that in previous years, teams have not been asked to explicitly separate these activities, and so have not been judged on exactly the same criteria listed above. But the overall approach of the exemplary projects we have identified captures the spirit of good HP work.

Best Integrated Human Practices

Imperial 2011

The 2011 Imperial team focused on P&P work that would inform the design and implementation of their overall project, which was about engineering bacteria to help fight

soil erosion and desertification. Impressively, the team gave equal weighting to experimental work, modelling, and P&P.

The team was interested in scoping out a variety of ethical, legal and social issues that might specifically influence the design and implementation of their AuxIn system (**aspect 2**). This is summarized nicely in the introductory paragraph to their HP work:

AuxIn

Imperial College London

Project AuxIn | Achievements | Human Practice | Extras | Team

Informing Design

We consulted numerous experts in various fields to ensure that the design of the AuxIn system respects all relevant social, ethical and legal issues. One module of our system, **Gene Guard**, is a direct result of brainstorming around the issues involved in the release of genetically modified organisms (GMOs). Although we have only reached the proof of concept stage, we have put a lot of thought into how AuxIn may be implemented as a product and the legal issues that would be involved.

Overview | Discussion Panels | GM Release | Legal Issues | Ecology | Implementation

http://2011.igem.org/Team:Imperial_College_London/Human_Implementation

To achieve this, they consulted with a range of stakeholders with different and relevant expertise, including companies, plant scientists and charities concerned with desertification (**aspect 2**). This is an appropriate method for the team to choose in the early design stages of a project, when you are trying to get a sense of key parameters, constraints and opportunities. By consulting experts based in different settings (academia, industry, NGO), the team is also able to incorporate multiple perspectives into the design of their system. The team provides nice clear [summaries of these discussions](#), and includes photos of the event.

The team also outlines very clearly how these consultations influenced their further HP activities, for example (i) the investigation of [legal issues](#) surrounding the release of genetically modified organisms, and (ii) the design of a ‘Gene Guard’ containment device with the aim of preventing horizontal gene transfer. Throughout their [description of the Gene Guard](#), they make clear links between their understanding of the broader context of application and the technical design choices they were making. This is a nice example that shows how HP work can inform aspects of the project’s technical design in clear and appropriate ways (**aspect 4**).

Chassis choice

1. Goal

In chassis choice, we had to consider several aspects. We wanted to choose a chassis that we would be able to transport to arid areas, preferably already enveloped inside a solid seed coat. In addition, we want the bacteria to be able to persist in the soil long enough to carry out their function. On the other hand, we also wanted to prevent spread of the bacteria into far-away ecosystems where they are more likely to have a detrimental effect on the ecological balance.

2. Action

We consulted two ecologists who are experts in above/below ground interactions and soil microbial ecology. They both advised us that while it may be more obvious to use naturally occurring soil bacteria such as *Bacillus subtilis*, *Escherichia coli* is less likely to survive in soil and may ensure better containment. Dr Alexandru Milcu pointed out that this is especially important considering that very high auxin secretion may skew plant populations. While this is not an issue in areas where the ecosystem is already badly affected, spread to other ecosystems, especially via spores, is a big issue. Dr Robert Griffiths also advised us that while engineering naturally occurring soil bacteria might lead to better persistence and cause our project to be more efficient, containment would be more easily achieved by using bacteria that do not normally occur in soil such as *E. coli* as they are more likely to be outcompeted.

These arguments caused us to pin-point our chassis choice on *B. subtilis*, a natural spore-forming bacterium that naturally occurs in soil and *E. coli*. We initially codon-optimised our genes for both of these species. At the first human practices panel, we thoroughly discussed the advantages and disadvantages associated with both chassis choices (Figure 1).

3. Result

Containment and possible contamination of other areas is a very big human practices issue. With *B. subtilis* as our chassis we would never be able to ensure complete containment. On the other hand, enveloping *E. coli* in a seed coat is mostly a mechanical issue that we should be able to overcome. We therefore chose to use *E. coli* as the chassis for Auxln.

Bacteria	Pro	Con
<i>E. coli</i>	Does not form spores, easier to contain, but has been surviving in the soil for more than 3 weeks without antibiotics	Difficult to implement in seed coat
<i>B. subtilis</i>	Spores are easy to incorporate into seed coat, give capacity for long term persistence	Spore-forming, can blow into other ecosystems and influence them negatively

Auxln

Figure 1. Our reasons for choosing *E. coli* as our chassis (graphic by Imperial College London iGEM team 2011).

<http://2011.igem.org/Team:Imperial College London/Human Containment>

In general, the HP information is very clearly presented on the team's wiki, making it easy for judges to see what work they have done and why. The overall aim and description of the HP work ('Informing Design') remains at the top of each wiki page relating to HP, keeping a nice tight focus. Crucially, the team also does a good job of narrating their HP work to help judges understand exactly how each HP activity has influenced their thinking and actions regarding their project (**aspect 2**).

From our **Human Practices panel**, we found that there were two important documents that we should study. The first is the **Rio Declaration on Environment and Development**, which is an international agreement for sustainable development that contains some very important principles. The second document is the **Cartagena Protocol on Biosafety**, an international agreement that seeks to establish guidelines for the safe release of GMOs without harming biodiversity. The articles that are relevant to our project are summarised below together with our approaches to make sure we comply with these rules.

<http://2011.igem.org/Team:Imperial College London/Human Legal>

Overall, the team did a significant amount of HP work (**aspect 3**), exploring a wide range of legal, technical, and social questions relating to the potential implementation of their Auxln system, and consulting several relevant experts who could help inform different types of choices within their project design.

Importantly, the team was also aware of the limitations of their work, making it a nice example for others to pick up and build on (**aspect 5**). For example, they highlight up-front that this is proof-of-concept work, and they also note on their wiki that ‘kill switches’ are never 100% effective, and explain how their containment device is an attempt to improve on existing technologies (but is not a silver-bullet solution).

The team’s approach to engaging with HP topics throughout their project was encoded in a detailed implementation plan. While previous teams had experimented with various elements of this approach, the Imperial team’s thoroughness, clarity, and combination of methods was considered by the judges to be a novel contribution to methods and understanding that could be adapted by other teams (**aspect 1**).

From the above, we can see why this HP project earned a high score from the judges. The team did a lot of work, and importantly they did a great job at explaining what they did and why they did it, and what effect it had on their thinking as their project progressed.

Best Education and Public Engagement:

Team Marburg. http://2014.igem.org/Team:Marburg:Policy_Practices

The 2014 Marbrug team is an excellent example of an innovative educational tool and public engagement activity that had the ability to discuss the science behind synthetic biology, spark new scientific curiosity and establish a public dialogue from voices outside the lab. The team was able to re-think their entire project and scientific questions in relation to sight. The the city of Marbrug is home to one of the only schools in Germany for the visually impaired. This team re-designed their own lab experiments in order to enable these visually impaired students to participate in the lab, by converting what they were seeing under the microscope into sound. They demonstrated not only why they designed these activities but also demonstrated how the activity changed their own perceptions on science.

Other notable teams:

2014 BGU Isreal – http://2014.igem.org/Team:BGU_Israel/Human_Practice1

They set up clinics and scholarship programs that would outlast their iGEM participation.

2012 and 2013 Purdue – created a community lab (sought non-profit status); created a biotech badge for girl scouts (this was in response to a STEM report the girl scouts put out. They addressed a gap another community identified with their outreach). These efforts aren’t continuing now, but they were good examples of ways to attempt to make lasting impacts.

http://2012.igem.org/Team:Purdue/Human_Practices

[http://2013.igem.org/Team:Purdue/Human Practices/Overview and Project Impact](http://2013.igem.org/Team:Purdue/Human_Practices/Overview_and_Project_Impact)

2014 Aachen - <http://2014.igem.org/Team:Aachen/Collaborations/Kaiser-Karls-Gymnasium>
The Aachen team developed a series of modules for introducing SB to high schools.

2014 Oxford - http://2014.igem.org/Team:Oxford/P&P_public_engagement

Measurement Approach

There are a lot of exciting Parts in the Registry, but many Parts have still not been characterized. Designing great measurement approaches for characterizing new parts or developing and implementing an efficient new method for characterizing thousands of parts are good examples. Teams interested in competing for the Measurement prize are *strongly* encouraged to participate in the Measurement InterLab study.

Specific Criteria

When judging the Best Measurement Approach prize, there are a handful of criteria you should be mindful of when scoring the team. Teams don't need to meet all of these, but it is recommended that they excel in at least one area.

1. Characterization of a Part: Did the team characterize one of their DNA Parts? If so, was it well done and do you consider their characterization to be complete? And did they document this work on their Team Wiki as well as the Registry?
 - a. Part characterization is an important aspect of Measurement in synthetic biology. For this prize, we look for excellence in characterization, whereby the team has convinced you that their part functions as expected with high quality data. Proper controls should be included in their measurement to be considered excellent.
2. Novel measurement approach: Did the team develop a new way to measure their Part? Did they build a measurement instrument? Or did they apply an existing measurement assay or tool in a new and innovative way to take their measurement?
 - a. Many teams take a creative and innovative approach to measurement. Teams that approach measurement with (a) a new tool, instrument, or assay, or (b) a new way to utilize an existing method, and then show that their approach works as expected, have achieved excellence in measurement.
3. Comparison to similar approaches: Did the team approach the measurement of their Part from various angles? Did they attempt multiple assays? Did they compare their new tool/instrument/assay with an established one?
 - a. When teams strive for excellence in measurement, they should also make sure they take the time to understand what came before and to think about what can be done to improve upon existing methods. This information should be clearly stated on their Team Wiki and the team should convince you that they did due diligence when considering their measurement approach.

Case Study #1: Penn 2013, Best Experimental Measurement Approach

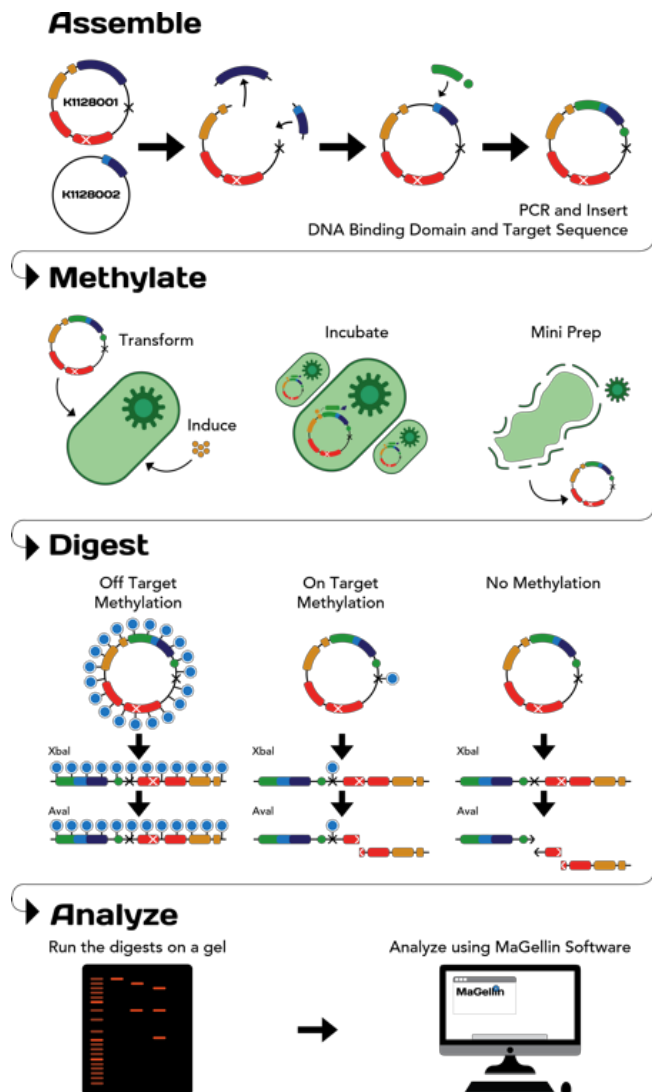

The Penn 2013 team focused on accelerating the development of an epigenetic engineering toolbox (workflow shown at the left). The team developed MaGellin, a novel assay to test and characterize the utility of various DNA binding domains to enable sequence-specific methylation. The assay was built into one modular plasmid and was validated in vitro and in vivo. It will simplify the workflow for synthetic biology labs with an interest in using DNA methylation as a control layer before transcription. They also developed a software package that automatically analyzes and interprets data from our assay, facilitating and accelerating the rate of characterization.

Case Study #2: Toulouse 2014, Undergraduate winner

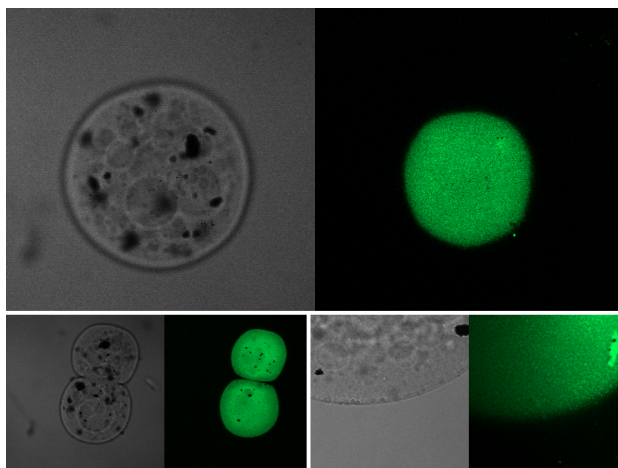

The Toulouse team developed a new protocol to test the chitin binding ability of their system using chitin magnetic beads. This test allowed the team to characterize their genetic device that had a chitin-binding domain in it and felt confident that it could be used with other BioBricks that display a chitin-binding domain on the surface of a cell. The great advantage of the test is that it allows quantification of how

many cells were expressing the chitin-binding domain through the use of a simple serial dilution, plating, and colony counting protocol.

The team also validated that the bacterial cells expressing chitin were attached to the chitin-coated magnetic beads using microscopy (as shown on the left). Through the use of a green fluorochrome (Syto9), they showed the presence of bacteria on the surface of the beads.

Models

Many (but not all) teams will construct mathematical models to aid in the design, understanding, and implementation of their work. Often these are models associated with gene expression and protein function, but teams have also modeled cell behavior, and the behavior of systems or processes of which their engineered devices play a part.

In general, there is an emphasis on models that *inform the design of parts or devices*, based on *real data*, using modeling methods *likely to be of use* in the community.

Let's consider a few examples. Analysis of gene expression using systems of ordinary differential equations is not unusual in iGEM. Stochastic modeling of the same equations is less common, though by no means rare. While [Colombia Uniandes 2013's](#) approach was not unique, they distinguished themselves by careful consideration and research of their model parameters (see figure to the right) - citing each and lending credence to the veracity of their model. (In iGEM, as in life, one encounters many models composed almost entirely of educated guesses masquerading as parameters.)

Parameter	Symbol	Value	Units	Notes	Source
Diffusion rate of Nickel	γ_N	0.5034	1/min		Basurco et al. "Evaluation of equilibrium, kinetic and thermodynamic parameters for biosorption of nickel (II) ions onto bacteria strain, <i>Rhodococcus opacus</i> " <i>Minerals Engineering</i> 22 (2009) 1318–1325
Dynamic constant for the entrance of nickel to the cell	k_p	4.63E-05	nM (nick)/nM (HoxN)*min	Original is 1.4pmol/(mg of protein*min). HoxN molecular weight is 33.1kDa. So we do the conversion. After 5 minutes the change of nickel is almost zero	Wolfram, Lutz et al. "The Alkaligenes eutrophus Protein HoxN Mediates Nickel Transport in <i>Escherichia coli</i> " <i>Journal of Bacteriology</i> . 1995 p. 1840-1843
Porine maximum expression rate	β	0.166	nM/min		Kalisky et al. "Cost-benefit theory and optimal design of gene regulation functions", <i>Phys. Biol.</i> 4 (2007) 229–245, doi:10.1088/1478-3975/4/4/001 (A cell volume of 1 μ l was assumed)
Association constant for DNA-RcnR complex	k_d	276	nM		Iwig et al. "DNA Recognition and Wrapping by <i>Escherichia coli</i> RcnR" <i>J Am Chem Soc.</i> 2009 August 19, 519.
Association constant of RcnR-Ni	k_x	21-29	nM		Iwig et al. "Ni(II) and Co(II) Sensing by <i>Escherichia coli</i> RcnR" <i>J Am Chem Soc.</i> 2008 June 18; 130(24): 7592–7606.
Repressor basal production rate	α_r	0.1	nM/min	Estimated order of magnitude	
Repressor destruction rate	δ_r	1/1200	1/min		Staniland et al. "Cell division in magnetotactic bacteria splits magnetosome chain in half" <i>Journal of Basic Microbiology</i> . 2010 January 14; 50: 1-5
Rate constant for the formation of the tetramer	k_T	0.82		Needs to be found with the model	Iwig et al. "Ni(II) and Co(II) Sensing by <i>Escherichia coli</i> RcnR" "One molecule of Nickel per monomer. The repressor is a tetramer." <i>J Am Chem Soc.</i> 2008 June 18; 130(24): 7592–7606.
Tetramer destruction rate	δ_T	1/1200	1/min		Staniland et al. "Cell division in magnetotactic bacteria splits magnetosome chain in half" <i>Journal of Basic Microbiology</i> . 2010 January 14; 50: 1-5
Cooperation	n	1.5-4	N/A		Iwig et al. "Ni(II) and Co(II) Sensing by <i>Escherichia coli</i> RcnR" "One molecule of Nickel per monomer. The repressor is a tetramer." <i>J Am Chem Soc.</i> 2008 June 18; 130(24): 7592–7606.
Porine basal production rate	α_p	3.3330	umol/min	It was considered that porine's production is linear and that the division of an <i>E. coli</i> cell takes 1/2 hour	Nikaido, Hiroshi. Berkeley University. Personal Communication. (2013, July 11).
Porine destruction rate	δ_p	1/1200	1/min		Staniland et al. "Cell division in magnetotactic bacteria splits magnetosome chain in half" <i>Journal of Basic Microbiology</i> . 2010 January 14; 50: 1-5

Team [OUC-China 2013](#) performed a simulation of the behavior of bacteria with an artificial magnetic organelle in a magnetic field. Their physical model was novel, and noteworthy for its direct comparison to real data from their experiments in a microfluidic device. The model and the data were also used to generate a general equation for magnetobacteria behavior in a magnetic field (see graphs below).

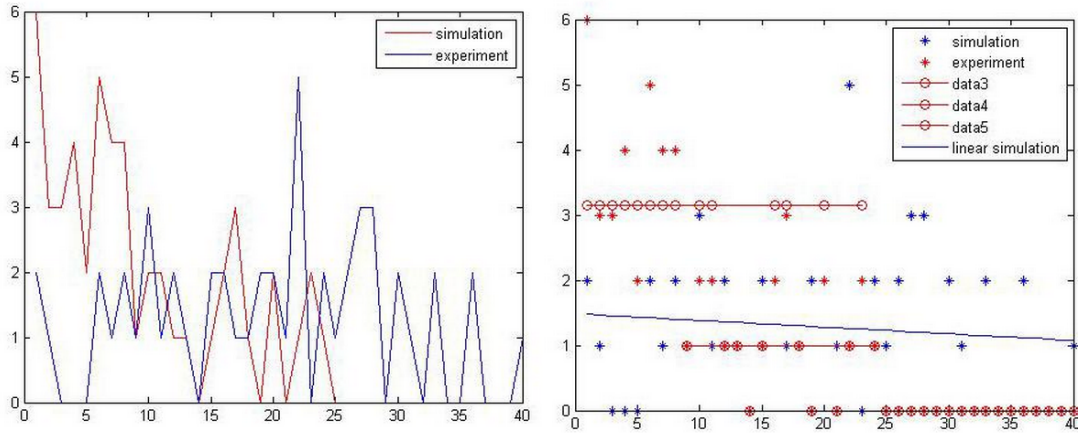

Team [Evy 2012](#) drew notice for generating a number of different models - using various techniques to model their system at a variety of length scales. This alone would have been impressive, but their work to integrate the various models - connecting them so that in the end measurable behavior could be modeled according to a series of interconnected models - was considered especially praiseworthy.

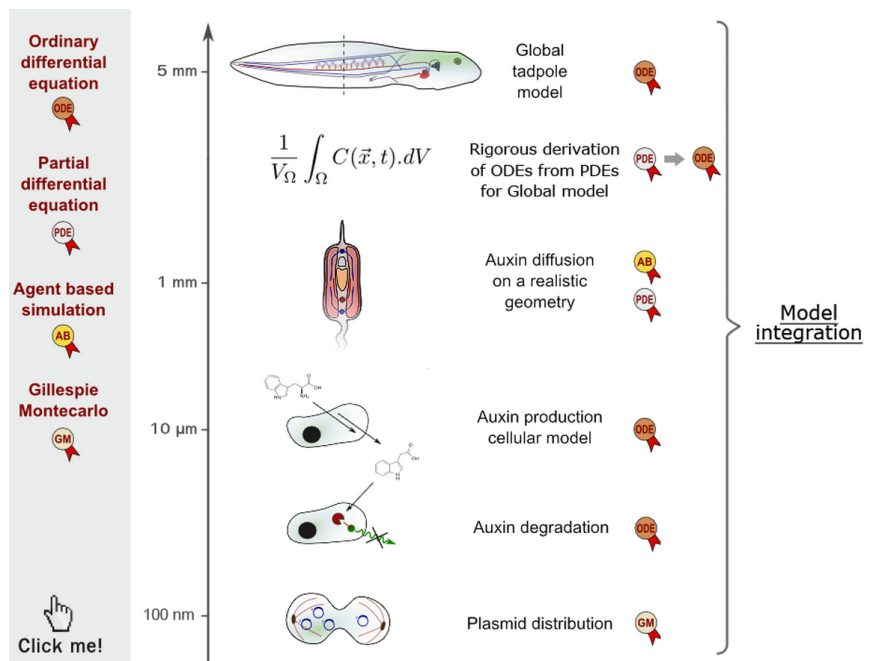

Likewise, [KU Leuven 2013](#) used their model not only to describe what was happening on the order of a single cell, but also on the order of a colony - influencing their design and probing the robustness of their oscillator. Perhaps more impressively, they also considered the functionality of their devices in the crop farming environment that they were designed for.

Wind speed

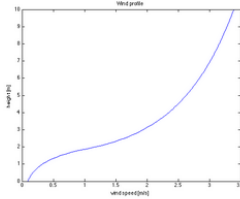

Figure 1 | Wind profile for a crop height of 2 m and a wind speed of 3.39 m/s at a height of 10 m.

Because of friction and obstacles on the earth's surface, wind speed varies with altitude. Generally, the velocity increases with increasing altitude. **A logarithmic wind profile is appropriate for the part above the crops** (Goudriaan, 1977, p. 96). The formula for this profile is

$$u = \frac{u^*}{k} \cdot \ln\left(\frac{z-d}{z_0}\right)$$

with u representing the velocity. Here d accounts for an upward shift above a vegetative cover. The relation $d=0.63 \times z_c$ is suggested, where z_c is the height of the crops. The length z_0 is called the roughness length and is often supposed to be about one tenth of z_c .

This model was used to determine the efficacy of their device and to better evaluate its potential impact.

In the iGEM rubric, there are four aspects for model assessment:

1. How impressive is the mathematical modeling?

Is the model chosen and performed well, using measured parameters from the literature? Did they consider the sensitivity of the model to various parameters? Are their assumptions reasonable? Do you buy their interpretation of the results?

2. Did the model help the team understand their device?

Did the team make design choices as a result of the model? Do they better understand the behavior of their device, or the impact that the device has on cells, cultures, the environment, etc.?

3. Did the team use measurements of the device to develop the model?

Did the team build and test a modeled device, comparing these measured results to their model to either improve or validate it?

4. Does the modeling approach provide a good example for others?

Would you suggest that future teams working on similar projects take a similar approach?

Let's consider these questions specifically as they relate to one of the examples: [KU Leuven 2013](#).

1. How impressive is the mathematical modeling?

KU Leuven performed [flux balance analysis](#), solved for a system of [ordinary differential equations \(ODEs\)](#) searching through a reasonably broad parameter space, and considered [physical convection](#) of their pheromone product in a farming environment. They applied a wide variety of techniques to various aspects of their system, and did so very effectively. Their parameters come from the

research and, when they are unknown, the team is up front about having estimated them (or searched a reasonable parameter space for them).

2. Did the model help the team understand their device?

Their flux balance analysis was used to determine culture conditions to maximize production, while the ODE was used to consider synchronization of oscillating cells that begin out of phase. The models were not merely constructed; they were used to answer specific questions about the system.

The practical results of their convection model are less clear, because of the number of unknowns, but the team lets us know that they haven't measurements for many of these parameters, and uses the model instead as a "back of the envelope" exploration of the usability of the system.

3. Did the team use measurements of the device to develop the model?

The results of their flux balance analysis were compared with experimental data gathered by the team.

4. Does the modeling approach provide a good example for others?

Flux balance analysis and solving a system of ODEs are nothing new to iGEM, but this team did a remarkably thorough job of both, and took care to use these models to answer legitimate questions about their project (rather than throwing up a bunch of disconnected models; modeling for the sake of producing graphs).

Presentations

All iGEM teams must give a 20 minute presentation at the Jamboree about their project. Having a successful iGEM project goes beyond the project itself as teams should present their work in a clear and engaging manner and communicate their project to a broad audience. *Above all, each team should tell a story as they present their work.* There are 5 aspects for assessment in the iGEM rubric that we should keep in mind as we evaluate presentations:

1. **Clarity of presentation: Could you follow the presentation flow?**
2. **How professional is the graphic design in terms of layout and composition?**
3. **Did you find the presentation engaging?**
4. **How complete is the team's effort to attribute work?**
5. **How competent were the team members at answering questions?**

To explore an example of an outstanding team presentation, let's take a look at the winner of the 2013 awards for Best Presentation, Europe, and Best Presentation, Undergrad (World Championship), [Dundee](#). First, you should definitely watch [Dundee's video](#) about targeting the toxin present in algal blooms:



Their presentation is truly engaging and literally “kept me on the edge of my seat!” (**aspect 3**). Rather than separate each part of the project and have a team member talk about just that part, they told a story, connecting the different parts of the project. They began with an overview of their project and described how the public was included in the project from its start. Rather than sticking the human practices component at the end of their presentation, they weaved HP into their story and addressed issues and concerns throughout the presentation.

The presentation flowed (**aspect 1**) and led the audience to ask what's next. The three presenters made smooth and effortless transitions during the presentation. Speakers maintained eye contact with good voice quality. Their presentation style conveyed their excitement and



ToxiMOP Splash! And the toxin's gone ...

Our problem: Algal Blooms

- Explosion in the growth of blue-green algae (cyanobacteria)
- Production of toxins
 - Hazardous to humans, pets and livestock.
- Local problem
 - E.g. Reservoirs, lakes/lochs
- Global problem

Clatto reservoir, Dundee

HUMAN PRACTICES Motivated by local issues with global reach

Current methods for dealing with algal bloom toxicity are far from ideal

- Existing methods target the blue-green algae not the toxin
- We were tasked with directly targeting the toxin

Dundee
iGEM 2014
www.dundeeiigem.org.uk

enthusiasm for the project. Additionally, they introduced humor at timely and sometimes unexpected points during the presentation to keep the audience engaged (e.g., “How much wood can a woodchuck chuck...”). Also, it was clear that they practiced their talk, as their presentation was polished and professional. They even anticipated questions from the audience; they included extra slides at the end of their presentation, just in case (**aspect 5**).

Now let’s focus on graphic design (**aspect 2**) – an impressive presentation would be error-free and need no verbal guidance. What can we say about the slides used in [Dundee's presentation](#)? One thing that immediately stands out is that the slides are really clean! What does that mean? The slides had high overall appeal and delivered a clear message. Here are some characteristics of those slides:

- Good quality and choice of images

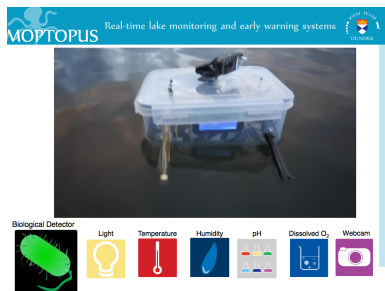

- Lots of visuals (i.e., not too much text)

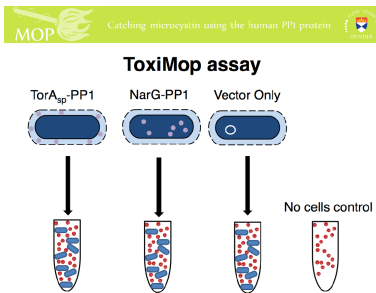
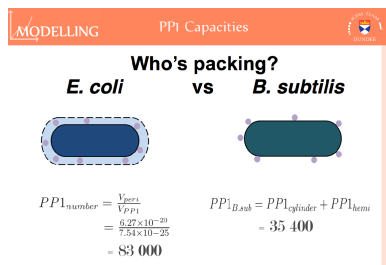

- Appropriate size for font and images (i.e., slides were readable)
- Well-labeled graphs with error bars

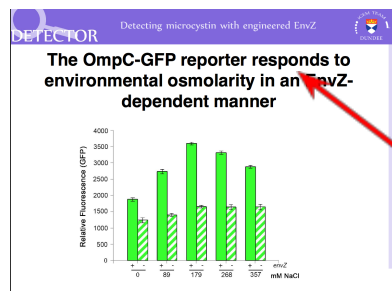
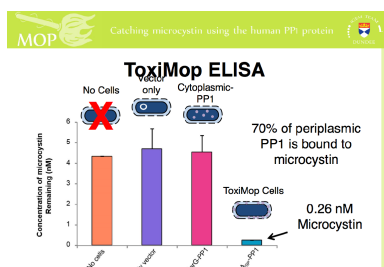

Clear take-home message

- Meaningful animations (i.e., nothing too fancy or flashy)

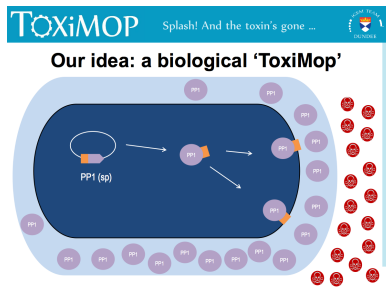

Another characteristic of a good presentation concerns the use of color. It's important that the choice and use of colors are not distracting and contribute to the understanding. During the presentation, Dundee used colors effectively in the headers on the slides (see figure below). Each major part of their presentation had its own header to serve as a visual guide to the audience. Throughout the presentation, it was easy to see where the current slide fit into the overall project. This creative use of color with specific images and descriptive text greatly contributed to the clarity and flow in Dundee's presentation.



In summary, the Dundee 2013 presentation was recognized for its excellence in clarity (**aspect 1**), graphic design (**2**), and engagement of the audience (**3**).

Wikis

In iGEM, the purpose of the team wiki is to publicly provide full project details to future teams and researchers in an organized, visually appealing manner. These details can and should include everything needed to reconstruct the project from the ground up, including the project goals, background information, research strategies, a lab notebook, experimental results, protocols, model documentation, results, safety information, BioBrick parts made, etc.

The wiki is the very first thing a judge sees when assessing one of his or her assigned teams, as the wiki evaluation occurs before the Jamboree begins. Characteristics like whether or not a wiki is informational, easy to navigate, or visually appealing can make a big impact on a team's critical first impression to the judging body. To explore an example of an excellent team wiki, let's take a look at the winner of the 2013 (and 2014) Undergrad Best Wiki award, [SDU-Denmark](#).

In the current rubric, there are five aspects for wiki assessment that we should keep in mind as we explore the team's wiki.

- 1. Do I understand what the team accomplished?**
- 2. Is the wiki attractive and easy to navigate?**
- 3. Does the team provide convincing evidence to support their conclusions?**
- 4. Will the wiki be a compelling record of the team's project for future teams?**
- 5. How complete is the team's effort to attribute work?**

Looking at the front page for the SDU-Denmark wiki (shown below), we can see that the color scheme and layout is visually appealing (**aspect 2**). It is formatted in such a way that the eye is drawn to the critical information – in this case, the motivation and basic idea behind their project: making rubber using bacteria instead of trees.

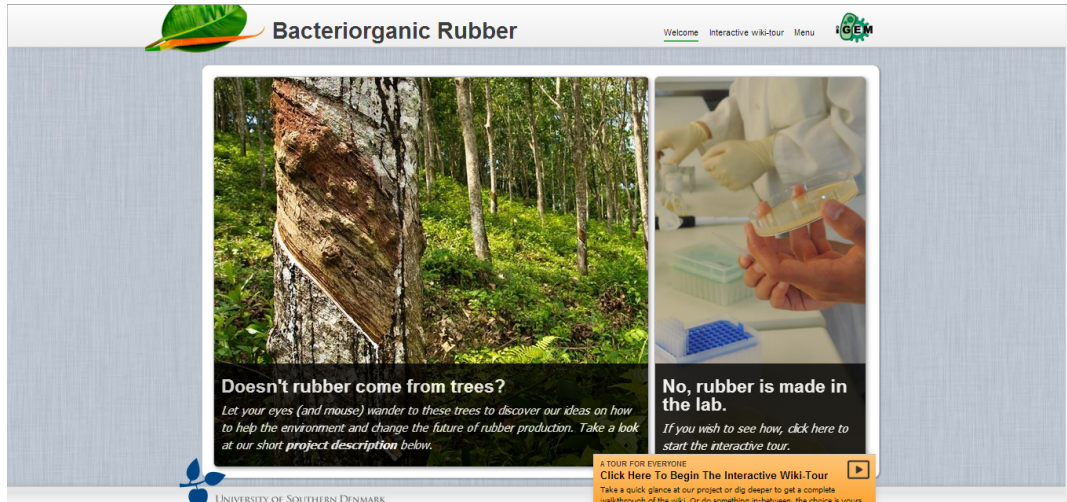

We also see an invitation to join an interactive tour of their project. While this type of feature is not required and is not necessarily standard, it allows the team to tell their story in the most advantageous manner possible. If we start the tour, we are taken to the page below:



Following standard scientific writing, the team has begun their story with a summarized “abstract” of their project (**aspect 1**). At the top of the page, we can also clearly see a navigation track (**aspect 2**):

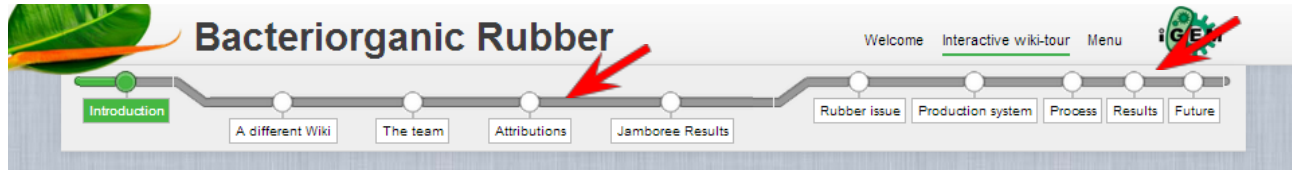

From the very beginning of their tour, SDU-Denmark has made it very easy for a judge to find the answers to **aspects 3** and **4** regarding data and attributions (see the red arrows). However, for a viewer less interested in these Jamboree-specific questions, one can simply skip to the next chapter (“Rubber Issue”) that deals more with the story behind their project. Navigationally, this wiki also allows a viewer to easily jump to any particular section of interest by hovering over the “Menu” link:

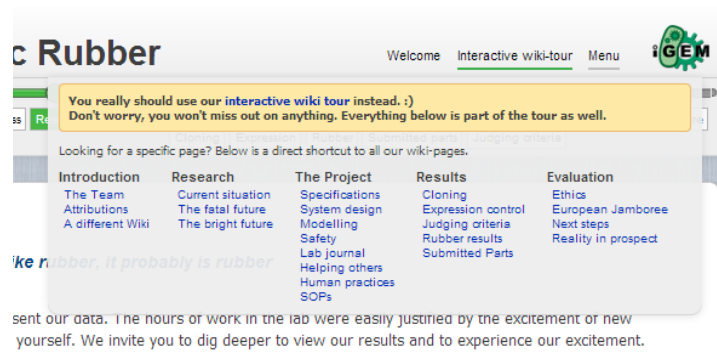

The ease of navigation of this wiki (**aspect 2**) is just one characteristic that makes it deserving of the Best Wiki award. If we look more into the “guts” of the wiki, we find a wealth of information about the project, including in-line links to their references (reached by hovering over the speech bubble icons) (**aspect 4**). The information is laid out in a way that is visually easy to read and uses language that is easy to understand (**aspects 1** and **2**). In the results section, we find detailed descriptions of their entire experimental process, including dozens of publication-level figures that can be opened up in-screen for more detail (**aspect 3**):

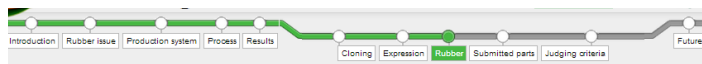

The conclusion arrives in figure 5, named DXS+PT, which is our double plasmid CPS bacteria, and displays the same peaks (A), (B) and (C) as both the WT + polyisoprene and pure polyisoprene. This is a strong indication of the presence of rubber - specifically, this is an indication that our CPS bacteria produces rubber: Bacteriogenic Rubber. Peak distortion of the spectrum due to solvents are the same as seen in the rubber purification from WT + polyisoprene.

A second round of testing was done to validate the first experiment. We wanted to include a negative test (WT), in order to exclude the possibility of a naturally occurring polyisoprenoid compounds in *E. coli*. We performed rubber purification on WT, our CPS bacteria as well as a strain containing only the pSB1K3-*araC*-*Para-HRT2* device. Bacteria were grown and rubber extracted as described above. The three samples where unfortunately not dried properly in the vacuum oven due to apparatus malfunction.

The test provided the following results: Fig 6 lacks the characteristic peaks of polyisoprene at 5.12, 2.04 and 1.68. It can be concluded from their absence that there is not rubber (nor any other compound that might provide a similar chemical shift values) in the wildtype. In the CPS (Fig. 7), we observe very a slight peak at 5.12, indicating the presence of (A) hydrogen. This peak has the same splitting pattern as the first round of $^1\text{H-NMR}$, but it has a very low intensity. The (B) and (C) peaks are hidden in the background noise, which is most likely due to cell debris and solvents, which did not evaporate appropriately. We suspect that the machinery has a decreased sensitivity towards the isoprene peaks due to the high amount of solvent seen from the assigned peaks, but the peak at 5.12 (with the recognizable splitting pattern) is a strong indication that rubber is once again present in our CPS bacteria (containing both HRT2 and Dxs plasmids).

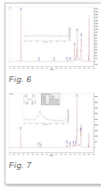

SDU Denmark made such a remarkable attempt at ensuring their wiki was of the highest standard for the 2013 Jamboree, that they won the best wiki award again in 2014 with the same design! The attention to detail, layout, navigation and ease of use make their design one of the most compelling wiki records in the brief history of iGEM (**aspect 5**).

Finally, it is important to note that this wiki also follows all of the [iGEM wiki requirements](#) (e.g., all pages, images, and files are hosted on the iGEM server, etc). If any content is hosted off-site, the wiki is automatically disqualified from the best wiki award. The winning wiki is the first teams will look at in subsequent years, so it must be the best exemplar in every way.

From the above, we can see why this wiki earned high marks in all four judging aspects. However, this wiki has some additional characteristics that facilitate judging for other categories in the rubric: (1) a page listing their accomplishments in terms of [medal criteria](#) and (2) direct links to their BioBricks in the Registry of Standard Biological Parts. Although these pages do not necessarily correspond to any of the four aspects for wiki assessment, they can be very useful to a judge before, during, and after a team's presentation when he or she is looking for the answers to specific judging questions. The availability and organization of the information reflects well on the team project as a whole. Finally, SDU-Denmark also makes their [wiki source code](#) available to all teams, demonstrating the sense of worldwide camaraderie and collaboration that is so important in iGEM.

Basic and Composite Parts

BioBricks are the main building elements of iGEM that allow other teams to build on the shoulders of the previous teams. Since many teams incorporate basic parts into new devices, the impact of good BioBricks can be seen for years in the iGEM and greater synthetic biology communities. While a basic BioBrick part composes a single functional unit, a composite part is an integrated assembly of interchangeable components that can function with some versatility, linking its elementary functions (transcription, translation, encoded protein) together to give a higher order function (regulatory device). There are four aspects in the current rubric for assessment that we should keep in mind as we evaluate parts (with minor differences for basic and composite parts):

1. **Basic Parts: How does the documentation compare to BBa_K863006 and BBa_K863001?**
Composite Parts: How does the documentation compare to BBa_K404122 and BBa_K863005?
2. **How new/innovative is it?**
3. **Did the team show that it works as expected?**
4. **Is it useful to the community?**

In 2014, the part status check system was incorporated into the part evaluation system. Judges now no longer need to individually look at each base pair to examine if it meets Registry standards. As this check is now automated, judging parts comes down to the quality of documentation, innovation, functionality and utility to the community.

To satisfy Registry guidelines, the part must (1) be sent to iGEM HQ by the deadline (see calendar of events for the deadline), (2) be in the pSB1C3 vector, (3) be BioBrick (RFC10) compatible or an agreed exception (on a case-by-case basis), (4) meet the standards set by the safety committee, and (5) be documented on the part page in the Registry.

Registry documentation should include:

- Basic description of the part
- Sequence and features
- Origin (organism)
- Experimental characterization
- Specific definition of the chassis and genetic context where it was demonstrated to work (and/or where it doesn't work)
- Potential applications
- Appropriate references from the primary literature

As a sample part evaluation, let's look at [BBa_K863006](#), a basic part which contains the open reading frame for *E. coli* laccase and was created by the [Bielefeld-Germany 2012](#) iGEM team. As seen in **aspect 1** of the rubric, this part is used to set an example for excellent documentation of parts, most of which can be found on the part main page (see figures below). Not only is there a lengthy paragraph describing the basic biology behind the part and its main usage (with a literature reference), but also there is extensive data describing purification, SDS-PAGE, MALDI-TOF analysis, and enzyme activity assays for the *E. coli* laccase under the control of T7 promoter with a His-tag (see [BBa_K863005](#) for additional information). Additionally, we can clearly see that this part is compatible with RFC10, as there is a green box labeled "10" next to "Assembly Compatibility" (see the red arrow). Therefore, this part is accepted in the part status check.

main page design experience information part tools edit

Part:BBa_K863006
 Designed by: Isabel Huber Group: iGEM12_Bielefeld-Germany (2012-09-18)

Released HQ 2013
 Sample In stock
 Experience: Works
 Not Used
 Get This Part

ecol laccase from *E. coli*
E. coli laccase ORF
 Sequence and Features

Subparts | Ruler | [SS](#) | [DS](#) Length: 1551 bp View plasmid Get part sequence.

1 200 400 600 800 1K 1.2K 1.4K 1.6K 1.8K 2K
 ATG TAA

Assembly Compatibility: 10 12 21 23 25 1000

Usage and Biology
 In the last few years a lot of attention has been drawn to laccases due to their ability to oxidize both phenolic and nonphenolic lignin related compounds as well as highly recalcitrant environmental pollutants. This makes them very useful for applications concerning several biotechnological processes. This includes the detoxification of industrial effluents, for example from the paper and pulp, textile and petrochemical industries. Laccases are also valuable as a tool as a tool for medical diagnostics and as a bioremediation agent to clean up herbicides, pesticides and certain explosives in soil. Furthermore these enzymes are also used as catalysts for the manufacture of anti-cancer drugs and even as ingredients in cosmetics^[1]. Their capacity to remove xenobiotic substances and produce polymeric products makes them a useful tool for bioremediation purposes. In our project laccases are used as cleaning agents for a water purification system. Laccases are

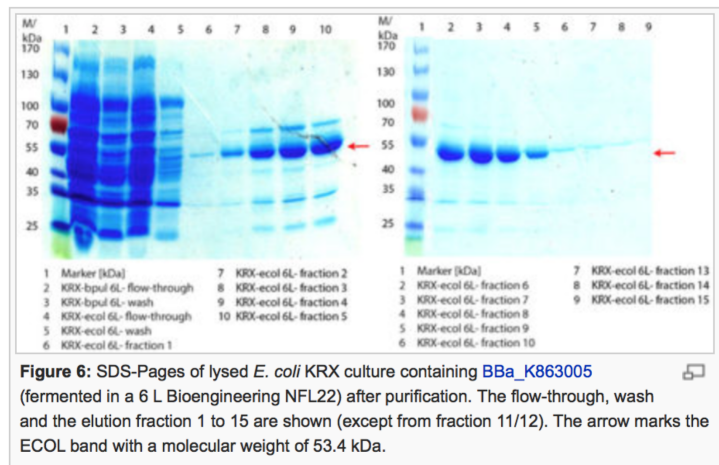

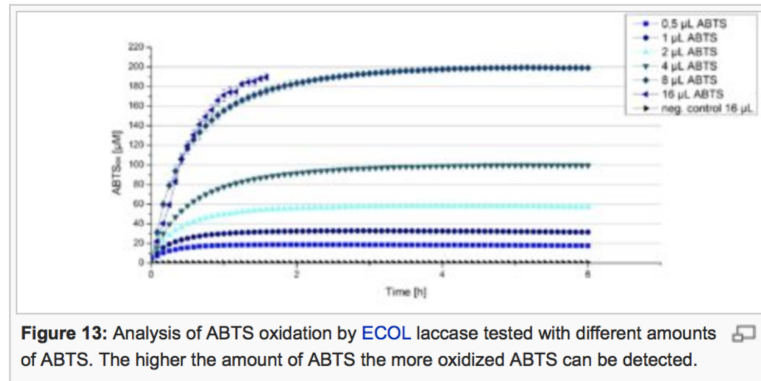

On the design page, we additionally find information about the source of the part and the primers that were used to isolate the gene, allowing other researchers to replicate the work:

Registry of Standard Biological Parts

main page design experience information part tools edit

Part:BBa_K863006:Design Released HQ 2013
 Designed by: Isabel Huber Group: iGEM12_Bielefeld-Germany (2012-09-18) Coding

ecol laccase from E. coli Sample In stock
 Subparts | Ruler | [SS](#) | [DS](#) Length: 1551 bp Experience: Works
 View plasmid Not Used
 Get part sequence. Get This Part

ATG TAA

Assembly Compatibility: [10](#) [12](#) [21](#) [23](#) [25](#) [1000](#)

Design Notes [\[edit\]](#)
 Primers for isolation of the gene with BioBrick Prefix in the fwd primer and Suffix in the rev primer.
 fwd: 5'-ACGTGAATTCGCGCCGCTTCTAGATGCAACGTCGTGATTTCTT-3'
 rev: 5'-ACGCTCTGCAGCGCCGCTACTAGTATATACCSTAAACCTAACA-3'

Source [\[edit\]](#)
 The gene sequence was isolated from *E. coli* BL21(DE3).

References [\[edit\]](#)
 Zeng, J., X. Lin, *et al.* (2011). "Oxidation of polycyclic aromatic hydrocarbons by the bacterial laccase CueO from *E. coli*." *Appl Microbiol Biotechnol* 89(6): 1841-1849.

Another good example of a basic BioBrick part is [BBa_K925000](#), which was created by the [St. Andrews 2012](#) iGEM team and won the Best New BioBrick Part, Natural. This part is a coding sequence of a Delta-12 desaturase involved in Omega-3 biosynthetic pathway. Although the Registry documentation includes sequence information and some functional analysis, there are a few issues with the part that, if addressed, would greatly improve its usefulness to the iGEM community:

- The part status box in the upper right-hand corner of the part page (see figure below) indicates that the part is unavailable, and it is unclear whether or not the part works.

- Since this part encodes only an enzyme, it must have been placed into some sort of device (containing a promoter, RBS, and terminator) in order to have been characterized. The part page does not specify the part number from which the characterization results were generated, nor does it state which promoter, RBS, etc., were used in lieu of referencing a separate part.
- There are no links to the wiki page of the project where we can read some other important details about part usage (including that the Part was transferred to the pET-Duet vector and used in *E.coli* strain BL21(DE3)).
- Since this part is derived from a natural source, it would have been useful if the team had also included a link to the UniProt sequence.
- Although there is a lot of experimental data on this page, the legends for the figures are not very detailed. In order to get the experimental details to understand the data, one is required to visit the team's wiki page. This is not ideal; instead, the Registry documentation should be able to stand alone.



For the most part, the process for judging basic and composite parts is identical. For basic parts, the focus is on conforming to Registry standards, since the ability to integrate into standard cloning systems is directly related to the parts' usefulness. For composite parts, the focus is more directly on usefulness, since composite parts can often function as standalone devices and do not necessarily need to be integrated with other parts.

Let's take a quick look at some examples of great composite parts:

Our first example is [BBa_K323135](#): VioA and VioB enzymes fused with zinc fingers under pBAD promoter. This part was created by the [Slovenia 2010](#) iGEM team and won the award for Best New BioBrick Part or Device, Engineered. Aside from being quite well documented, this part worked, was well-documented, and had a useful, novel function. This part simply and effectively demonstrated how simple protein domains could be assembled into a higher order organization using a DNA-guided mechanism to put functions of interest into the

correct location and orientation for efficient bioprocessing. This essential idea of DNA program-guided zinc fingers proved to be quite useful to the community. Not only did it open up the field of engineered subcellular-level localization and spatially-sequential processing, but it was adopted by later iGEM teams, including [NCTU Formosa 2012](#), who incorporated the exact design into their project to improve fermentation of isobutanol.

A second example is [BBa K1150020](#): uniCAS Activator (CMV promoter). This part was created by the [Freiburg 2013](#) iGEM team and won the award for Best New BioBrick Part/Device, Engineered in Europe. Again, this part had excellent documentation, conformed to RFC#10, and had data demonstrating its working function. Even though CRISPR/Cas had already been popularized within the biology/bioengineering community, the uniCAS project brought this powerful tool into the iGEM community and provided a standardized collection of parts (exemplified by this part) which will likely serve as the foundations for other teams who wish to use the CRISPR/Cas system. In fact, the collection has already made its appearance in this year's "Featured Collection" in the Registry.

Entrepreneurship

Entrepreneurship has always been a part of iGEM, even though there have not always been prizes to recognize the effort. From 2012 to 2014, iGEM hosted an entrepreneurship track which allowed teams to compete but with their main focus being on business ideas instead of synthetic biology.

Starting in 2015, achievements in entrepreneurship are recognized with a special prize instead of a track. The focus of the prize is on ideas taken from lean Launchpad and customer discovery^[JB1]. In other words, teams are encouraged to go speak to potential customers during the initial design phase of their project. The reason for this emphasis on customer discovery is that customer-focused approaches correlate well with business success to a higher degree than teams working solely on business plan and pitch competitions.

Case Study 1: Benchling

To explore entrepreneurship in iGEM through a customer-focused case study, we will look at {Benchling}[http://2012e.igem.org/wiki/index.php/Team:MIT_E]

page discussion view source history Log in



Your DNA swiss army knife

Annotations, BLAST, plasmid maps, primer design, and more without leaving your browser.

Benchling makes it easy to edit, analyze, and share DNA sequences.

Get Started with Benchling for Free

About Business Team Contact

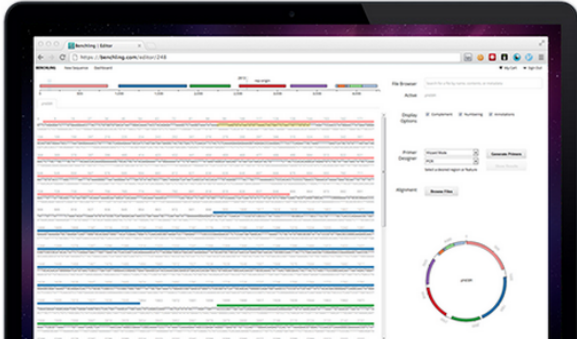

Forget file formats

We do the dirty work. Import and export to a growing list of file formats.

Analyze data instantly

All the standard algorithms you love, under one interface. No more command line tools. Get beautifully formatted output or raw data if you want to go under the hood.

Collaborate seamlessly

Give your colleagues access to your data. Search and share across your lab.

Organize your data

Stop updating an Excel spreadsheet. Tag your data and organize it in a way that works for you.

Figure 1: Benchling 2012 wiki

The MIT team in the first year of the entrepreneurship competition chose to build software to make editing, analyzing and sharing DNA sequences much easier. They ran their software on several Amazon web servers which continue to operate as they have built their business: <https://benchling.com/>.

Although the judging criteria by which Benchling were evaluated have changed since 2012, the project that resulted from their efforts is still the type of project we are looking for today. We will retrospectively apply today's judging criteria to their project to show how they performed and illustrate the type of projects we are seeking.

Benchling set out to make DNA editing software that was better than everything else on the market. At the time, their competitors were programs such as Vector NTI, a plasmid editor (APE), and online web-based tools such as Synbiota. Realistically, however, many scientists were still using non-specialized programs like Word or Excel to manage DNA design. Benchling needed to offer something that was cheap/free, user-friendly, reliable to avoid loss of data, and used version control. The tool they built did all of these things.

Judging analysis

Rubric Aspect 1: Customer Discovery - Has the team interviewed a representative number of potential customers for the technology and clearly communicated what they learned?

Benchling had their product in the hands of researchers at Harvard, MIT, UC Berkeley, UCSF and UC Santa Cruz before the wiki freeze. Altogether, these institutions likely had many, many users in total, allowing Benchling to get feedback quickly. As their product was entirely accessed online, they could iterate versions and incorporate requested changes as fast as they could code.

Rubric Aspect 2: Based on their interviews, does the team have a clear hypothesis describing their customers' needs?

At the time, the DNA analysis software on the market was either expensive, had a poor user interface, was not reliable, did not do version control, or possessed a combination of these issues. Benchling set out to make the best product on the market by addressing these issues with their minimum viable product (MVP).

Rubric Aspect 3: Does the team present a convincing case that their product meets the customers' needs?

From the 2012 Benchling wiki: "Benchling is a platform for life science data management. It allows scientists to edit, analyze, and share DNA sequence data. Scientists build with DNA, just like programmers do with code. Major biotech companies account for 2% of the US

GDP. Despite this value, there is no version control in life science. These companies have no cloud-based tools for facilitating collaboration and sharing between their scientists."

Rubric Aspect 4: Has the team demonstrated a minimum viable (MVP) product and had customers to commit (LOI, etc.) to purchasing it / using it?

The online demo of the Benchling MVP was successful enough to gain early adoption in at least 5 major research-focused institutions before the 2012 wiki freeze. Not only did Benchling build an MVP, but they were actively working with users to develop their product during the competition. While this model currently applies much better to software than synbio, the field is advancing rapidly and development cycles relying on DNA synthesis assembly are constantly shrinking. It was not clear from the Benchling wiki if they had paying customers in their user base.

Rubric Aspect 5: Does the team have a viable and understood business model/value proposition to take their company to market?

Benchling initially set out to make their tool free to use for students but with a pay subscription model for faculty, labs and industry. Their strategy was successful as by fall 2013, they had thousands of customers in many academic institutions all over the world. Again, the freemium model is common in software development, but has yet to gain traction in the synbio industry.

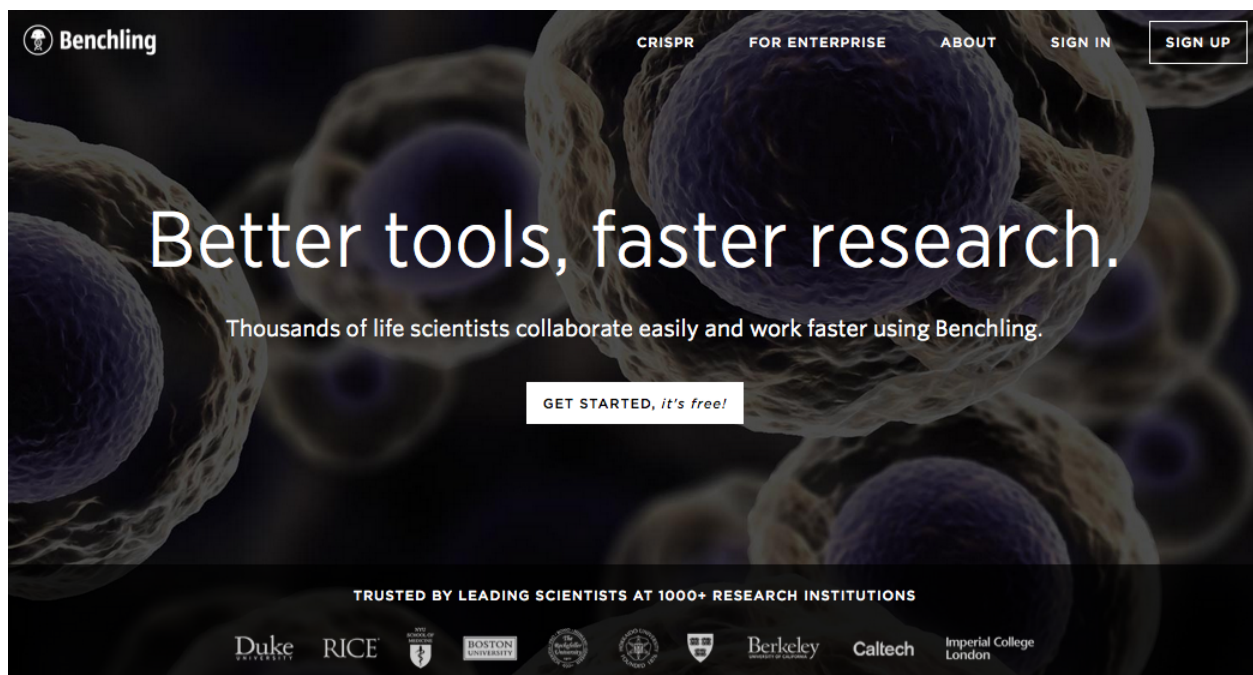

Figure 2: Benchling in May 2015

Benchling are still in operation as of May 2015. After the 2012 entrepreneurship Jamboree, they relocated to San Francisco and in April 2015 received a \$5M investment from Andreessen Horowitz:

<https://www.pehub.com/2015/04/andreessen-horowitz-and-thrive-capital-fund-benchling/>

Case study 2: Darwin Toolbox:

The Darwin Toolbox is a hardware project presented by the {2013 University College London iGEM entrepreneurship team}[http://2013.igem.org/Team:UCL_E]. They wanted to address lack of widely available synbio tools by making a cheap, safe, user-friendly lab-in-a-box for high schools and community labs.



Figure 3: 2013 Darwin Toolbox prototype and 2015 Bento Lab version

They built a functional prototype lab and brought it to the Jamboree, but it was unclear if they had incorporated user feedback into their device by the time of the Jamboree or if they had any committed customers.

After coming across some trademark issues, Darwin Toolbox rebranded as Bento Bio and have continued to work on their project: <http://www.bento.bio/>

Case Study 3: FREDsense

FREDsense was the {2013 Calgary Entrepreneurship team}[http://2013.igem.org/Team:Calgary_Entrepreneurial] project.

This project was continued from the 2012 North America regional championship award-winning Calgary project, with a focus on commercialization. The team focused on

building their environmental toxin sensor into a product that was adapted to address pollution concerns surrounding shale oil production in Northern Alberta. They are the only team among these examples to use their biological product in a commercialization environment.

Before attending the Jamboree, they filed a provisional patent to protect their ideas against disclosure in a public forum, showing forethought in terms of IP strategy.

The team won the entrepreneurship division in 2013 and went on to build a business after the Jamboree: <http://www.fredsense.com/>. It is not clear how much they talked with customers or had letters of intent to purchase functional prototypes of production units of their sensor before the 2013 Jamboree.

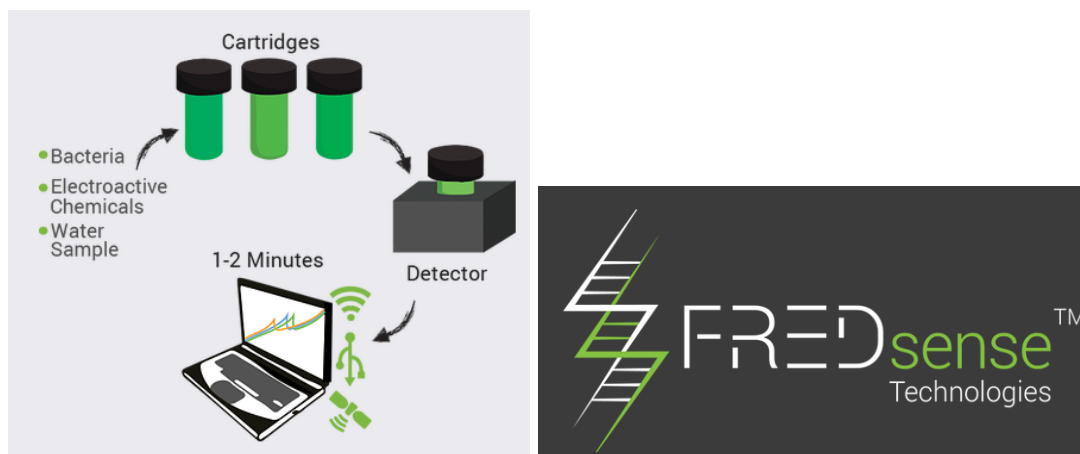

Entrepreneurship in iGEM enters a new phase in 2015. An award replaces a track, allowing any iGEM team to consider how to build a company and get feedback on their project.

Giving teams the opportunity to work on commercialization as part of their project could incentivize some teams to continue their work after the Jamboree. Teams may even consider applying to an incubator or accelerator after iGEM. The aim with this prize is to create the opportunity space and see what happens.

Applied Design

The Applied Design prize is awarded to the team that has developed a synthetic biology product to solve a real-world problem in the most elegant way. The students will have considered how well the product addresses the problem versus other potential solutions, how the product integrates or disrupts other products and processes, and how its lifecycle can more broadly impact our lives and environments in positive and negative ways.

Case Study: Imperial College London 2014

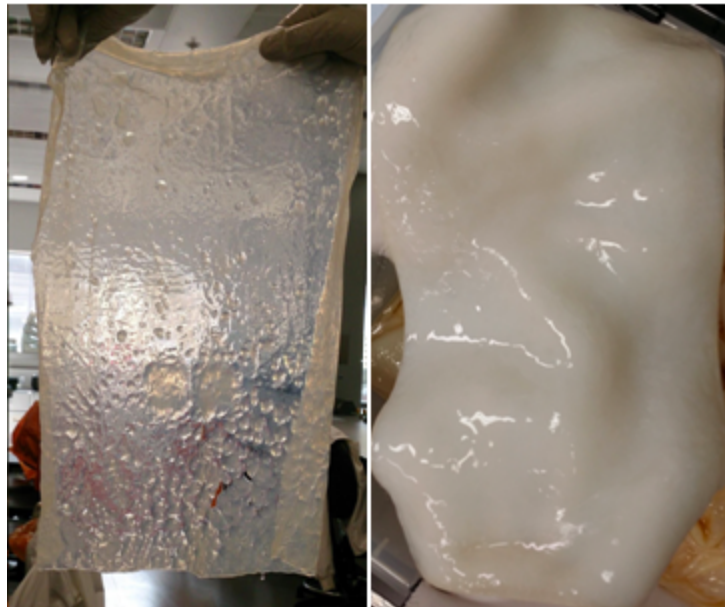

Imperial College London 2014 used bioengineered bacterial cellulose, commonly associated with kombucha, to create a water filtration system. The team engineered the bacteria to produce metal binding enzymes, which would better capture metals like zinc and nickel as water passed through the filter.

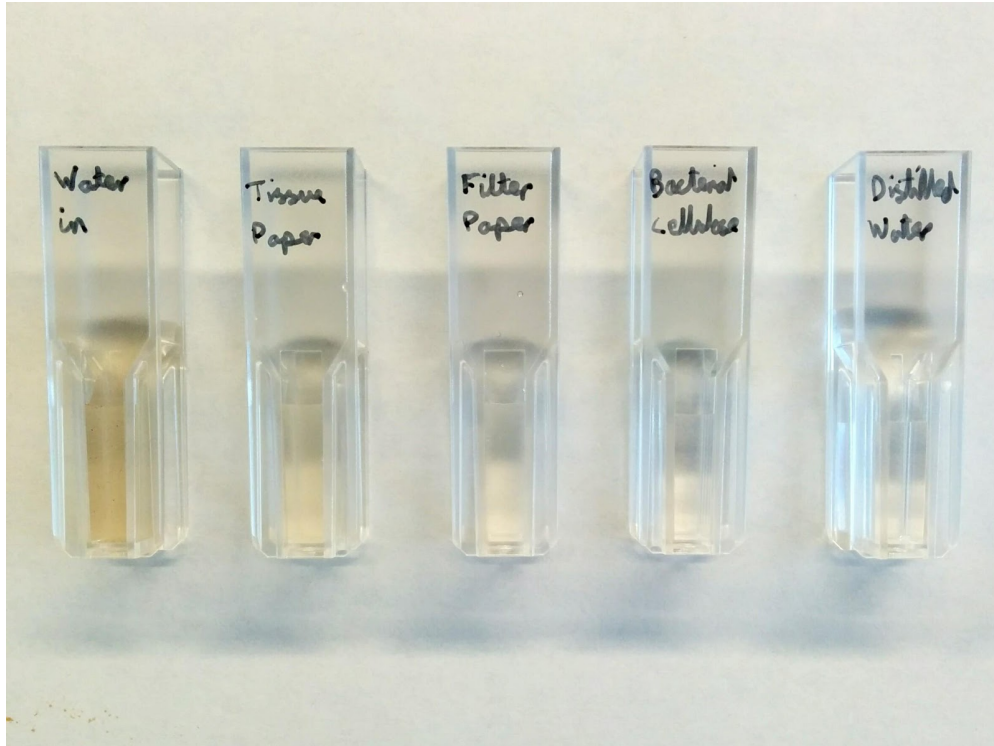

The project was impressive in a number of ways. The team members worked with designers to brainstorm applications for their bacterial mat before settling on water filtration as their goal. Crucially, they also met with experts in the field of water purification—including Thames Water, a private utility company responsible for water supply and wastewater treatment in large parts of London, to more deeply understand the problem they were trying to solve and understand how their project might fit into existing infrastructures.

Posters

In iGEM, the purpose of the poster is to communicate the project to others in a very concise, yet engaging manner. In the past, posters have been too “busy” and “unbalanced” in regards to text, figures, and space, forcing poster judges to look at other criteria when choosing the poster winners. We would like to turn things around this year by emphasizing the importance of balance and visual appeal in this form of scientific communication. There are six aspects for assessment that we should keep in mind as we evaluate posters:

1. **Clarity: Could you follow the poster flow?**
2. **How professional is the graphic design in terms of layout and composition?**
3. **Did you find the poster appealing?**
4. **How complete is the team's effort to attribute work?**
5. **How competent were the team at answering questions?**

The following details about poster format, poster components, poster evaluation criteria, and poster judging process are on the 2014 iGEM wiki (see [poster judging guidelines](#)).

Posters must conform to the following requirements (posters not conforming to these requirements will not be eligible for any special prizes):

- Dimensions = 4 ft. X 4 ft. (1.219 m X 1.219 m)
- Font size must be readable from a distance. *Recommended* font sizes are:
 - 44 pt for headers
 - 38-40 pt for body text
 - 18-24 pt for captions beneath figures
 - 18 pt for references

Expected iGEM Poster Components

Poster judges will expect the following components to be present in some manner:

- Title
- Authors and their Affiliated Institution(s)
- Introduction
- Methodology
- Results/Conclusions
- Acknowledgments
- Funding Attributions (If Applicable)

Past iGEM teams have also elected to include additional components on their posters such as:

- Abstract
- Objectives

- Motivation
- Team Achievements
- Future Directions
- Human Practices
- Parts Submitted

In addition, some teams have elected to display supplemental materials at their poster station. These displays have included laptop/tablet presentations, team prepared pamphlets/handouts, and 3-D printed models. *The supplemental materials will not be factored into the judging of the poster.*

Poster Evaluation Criteria

The following criteria are used to evaluate the posters:

- **Ability to Stand Alone:** The poster should be able to stand alone as a clear communication of the project without the team present.
- **Balance:** The poster should be a balance of text, figures, and space. Excess text should be avoided - figures should play a dominant role in communicating the project on the poster. There should be adequate space around text and figures to avoid a crowded appearance. *Judges will place heavy emphasis on balance.*
- **Overall Visual Appeal:** Color and font changes should be used appropriately. The use of too many colors creates an unprofessional appearance. Dramatic colors should be used only to illustrate dramatic points – overuse is simply confusing. There should be consistent use of color throughout the poster to represent the same concept - the colors should not be randomly switched. Due to red-green color-blindness, use of these colors to represent contrasting concepts should be avoided. *A poster with overall visual appeal stands out among other posters.*
- **Legibility:** The poster should be easy to read. There should be high contrast between the text and background. The background should not be busy and distracting. The resolution of the printed poster should be high enough that the text is clear and there is sharp detail on the figures. Avoid use of poor quality micrographs and other images on the poster. *Poster text and figures may appear clearer on screen than on paper; therefore, a printout of the poster should be viewed prior to display.*
- **Quality of Graphics:** The key concepts of the project should be diagrammatically represented. It is ideal if a single figure represents the entire concept. Figures should be well labeled and have clear legends. *It should not be necessary for presenters to explain the figures.*
- **Conciseness** – The content of the poster should be technically written. *It should take no longer than 10 minutes for someone to read the poster.*
- **Flow** – The poster content should follow a logical sequence. *The reader should be able to navigate the poster with ease.*

- **Appropriate and Relevant Content:** Careful thought should be put into selection of poster content. *Redundancy in the presentation of information becomes tedious and exists at the expense of other information.*
- **Accuracy of Information Presented:** The scientific content of the poster should be accurate. Models should be free of mathematical error. *The poster reveals the STEM literacy of the team.*
- **Grammar/Spelling:** Posters should be critiqued before printing for spelling and grammar errors. *Scientific names and mathematical units should be presented correctly.*
- **Attributions:** The poster is an opportunity to give credit to contributors who may not be present, and also to other scientists (e.g. earlier workers or competitors). *Attribution should be for key concepts and not details (i.e. ~ 5 references but not 20).*
- **Oral Presentation of Poster:** The poster presentations provide judges the opportunity for detailed probing. The team should be able to answer in-depth questions. *This is the opportunity for judges to find out if team members really understand the project.*

Poster Judging Process

The posters will be critiqued by a team of poster judges prior to the poster reception. The posters will be judged at this time to ascertain if the posters can stand on their own as clear communication of the project. *Presenters should not approach the judges during this time.* During the poster reception, this team of judges will be visiting the posters and discussing the projects with team members. Evaluations of both the displayed poster and the oral presentation of the poster factor into the awarding of the *Best Poster* prize. Teams should be cognizant of the fact that judges involved in the awarding of iGEM medals and other prizes may utilize the poster reception as a resource for making decisions on those awards. *In other words, all teams should strive to generate a high quality poster!*

Judges have the following expectations of teams at the poster reception:

- Posters need to be set up for display by the deadline provided. *Judges will be critiquing the posters before the poster reception commences.*
- All team members should be present throughout the poster reception. Keep in mind that the team members have expertise in various components of the project. *Inability of the team members who are present to correctly answer questions during the judges' visits negatively impacts the entire team, as well as its advisors and sponsors.*
- Teams should not select a single spokesperson for the team, nor should a single team member monopolize the oral presentation of the poster to the judges. *Judges expect a "team" presentation of the poster, so make certain that all team members are prepared to contribute if called upon.*

- Other members of the iGEM community may be visiting your poster when a judge arrives at the team poster. Teams should inform other visitors that they will have to return later because a judge is now present. *Judges should be given top priority during the poster reception because they have limited time to complete their judging responsibilities.*
- Your oral presentation during the poster reception needs to be concise due to time constraints. *If a judge requests a brief explanation, do not provide a lengthy one.*

Let's look at two examples of winning posters. [Macquarie Australia 2013](#) won the Best Poster, Asia, Overgrad. Their poster has high visual appeal and shows a good balance of figures and text with appropriate use of white space. The poster is fairly easy to read with contrast between the text and background and an appropriate choice of background. Most of the figures/images on the poster are high quality. The resolution of the Gibson Assembly diagram could be improved as it is a bit fuzzy as presented here. The font used to label the axes on the activity assay figures should be enlarged so it's clearer. Additionally, the figure legends need additional information to make this poster "stand alone." Appropriate and relevant content was selected and the flow of the poster is logical and easy to follow.



- In 2009 Australia relied on non-renewable energy from fossil fuels for 95% of its energy needs - 41% coal, 36% oil and 19% gas attributed to this. Successful production of chlorophyll in a bacterial host is the first step towards the synthetic construction of photosystem II, and the eventual creation of a new renewable energy source
- Our project aimed to express the thirteen genes (from *Chlamydomonas reinhardtii*) necessary for the chlorophyll biosynthesis pathway in a bacterial host (*Escherichia coli*)

Background

- Chlorophyll is the green pigment responsible for the absorption and transfer of light energy
- During photosynthesis, light energy is converted into chemical energy:

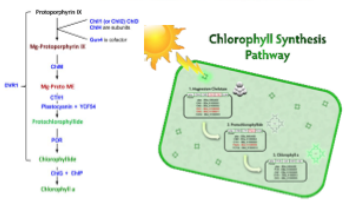

- *C. reinhardtii* is an algae that synthesises Chlorophyll a from protoporphyrin IX through a multistep pathway
- *E.coli* uses protoporphyrin IX in the production of heme
- A branch in the heme synthesis pathway will allow the use of *E. coli* as an expression host to create chlorophyll

Results and Characterisation

- **Gene Sequencing Results** - All of our genes were assembled correctly from gBlocks, all our sequencing results were submitted, and came back with an identity match of 100%

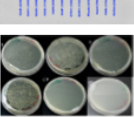

- **Composite parts:** Tac promoter BBa_K864400 was successfully ligated with the genes: CHL1, CHL2, GUN4, and Plastocyanin for further characterisation



- **CHL activity assay:**
 - CHL from the extract was used to form the magnesium chelatase complex with purified CHL1, CHL2, CHLH and GUN4 (Zhou et al. 2010 FEBS letters 586 (3), 205-210)
 - The increasing fluorescence signal shows Mg-protoporphyrin formation indicating a complex containing functional CHL has formed.
 - 1µL of cell extract had 2.1ng of active CHL protein

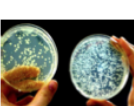

- **Plastocyanin:** chloroplast precursor - involved in electron transport
- Plastocyanin produces a copper chelated protein
- When exposed to an inducer and copper *E.coli* expressing this gene will turn blue (right plate)

Methodology

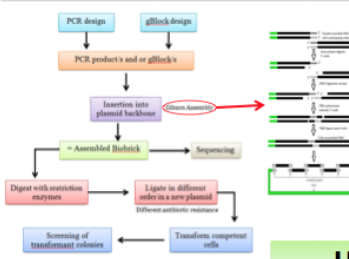

Conclusion

- Successfully constructed 12 BioBricks
- Designed 3 operons necessary for chlorophyll biosynthesis
- Improved understanding on how to manipulate plant genes
- Initiated reproduction of photosystem II to act as a cheap and efficient renewable green energy source
- New sources of electrons and hydrogen gas to combat the energy crisis

Human Practices

- Australasian Conference of Undergraduate Research**
 - Winner- Best Presentation in Molecular Biology or Plant Science research
- Education**
 - Presented 2nd year uni lecture on synthetic biology
 - High school synthetic biology workshops
- Synthetic Biology Conference**
 - Organised first conference in Southern hemisphere
- Synthetic Biology Society**
 - Initiators of SynBioNet Society
- Quarantine**
 - Recommendations for easy access to information on international standards for shipping regulations
- University Open Day**
 - Organised a variety of laboratory activities for members of the public
- Collaboration With Sydney Uni iGEM**
 - Helped promote the Strange Nature writing competition
 - Mentor program



M. Gibbs, D. Logel, M. Trouch, S. Chan, B. Brown, K. Gadsby, K. Blackshaw, A. Van Lierop, R. Sharma, H. Campbell, N. Dissanayake, A. Ryan, A. Mir, D. Russell, E. Cooper, D. Ubiparipovic, J. Phillips, D. McCarthy, C. Steel, A. Mala, F. Habi Almatini, A. Hammonds



Heidelberg 2013 won Best Poster, Europe, Undergrad. This poster does a great job using color to guide the reader in navigating the poster—it's easy to tell which part of the poster goes with the summary in the center of the poster. The quality of the visuals is good and all of them contain labels; however, there are no clear figure legends and it's likely the team

needed to be present to explain the poster. While there is a good balance of text and figures, the poster is heavy on methodology and consequently does not flow well.

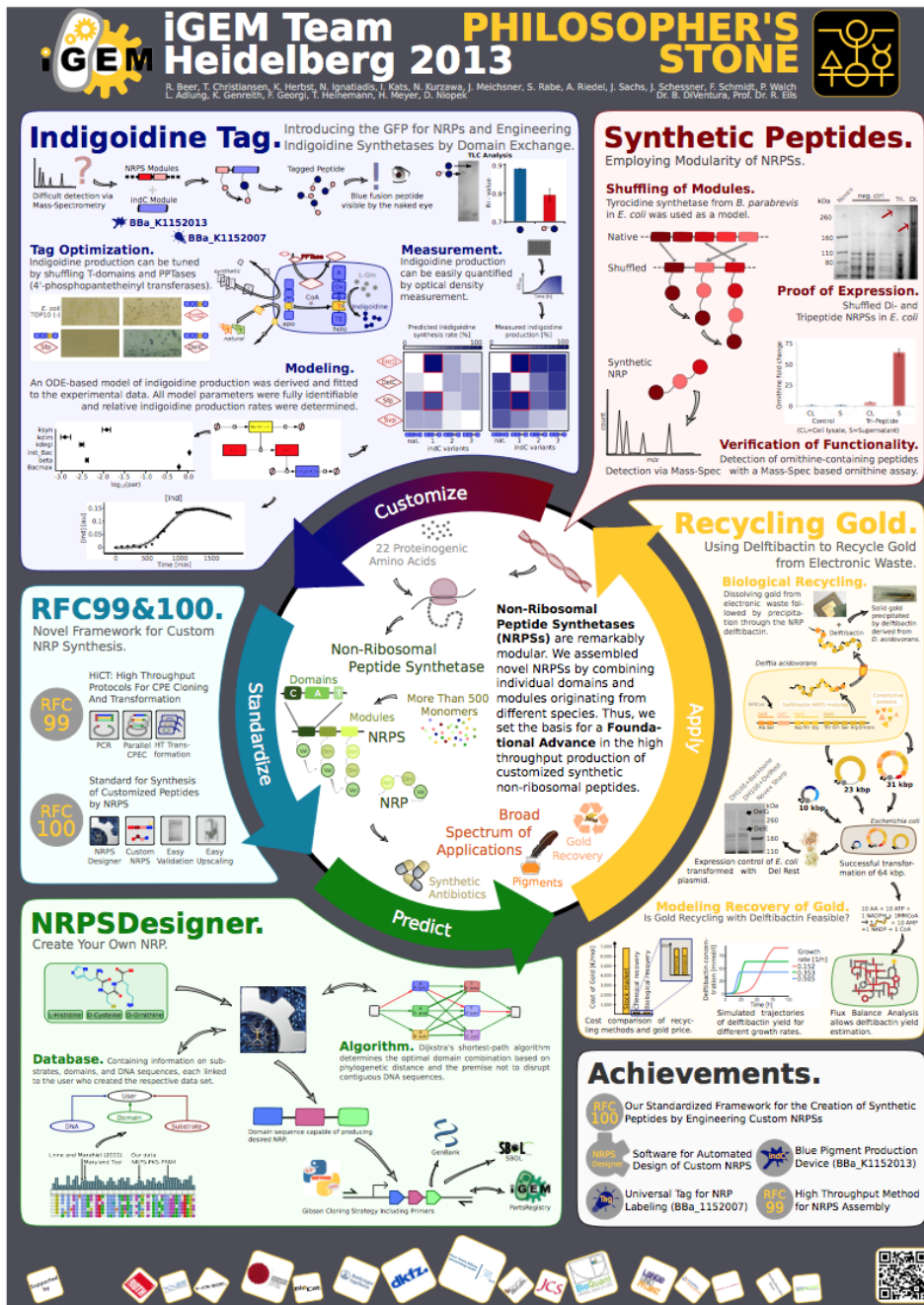

Software Tool

Software awards have been part of iGEM in different forms and shades since 2008. Nevertheless, there are quite a few changes compared to previous years, so we here try to illustrate our current priorities for judging software projects. Today in iGEM Software, we put emphasis on encouraging teams (1) to create closer links to experimental work and (2) to avoid re-inventing the wheel and making their work more re-usable and useful for future developers. This has lead us to reformulate medal criteria and rubric questions. Before getting started, judges should (re-read) the {current softare track page}[<http://2015.igem.org/Tracks/Software>] page. This Wiki page was made available early on and it was the main guideline for teams over the summer.

Medal criteria, in particular, have been tightened. For example, the Silver criterium #4 -- “best practices in software development” -- may be, depending on how it is handled, pretty tough on young teams. Judges should keep this in mind and interpret these new criteria such that most teams still have a good chance of earning Silver or Gold medals.

For the **general ranking**, including the possibility to win the Grand Prize, software teams are judged by the same 8 rubric aspects as everyone else -- starting from “How impressive was the project?” down to “Did they do the project themselves?”. Only aspects 9 and 10 are replaced by a more software-specific version:

9. How useful is the software for bio-engineering?
10. Is the software prepared to be extended and modified by other developers?

Software track judges then also have to answer 5 additional aspects to determine the winner of the **Best Software Award**:

1. How well is the software using and supporting existing synthetic biology standards and platforms?
2. Was this software validated by experimental work?
3. Did the team use non-trivial algorithms or designs?
4. How easily can others embed this software in new workflows?
5. How user-friendly is the software?

We will now use the [“Autogene” project](#) from the Johns Hopkins Software team 2012 as an example. Autogene was the co-winner of the 2012 software track (together with the project from the [UK Tokyo](#) team). Let's see why Autogene is a deserved winner and how it would fare with the new judging rules. The team has summarized the different components of their work on their Wiki:

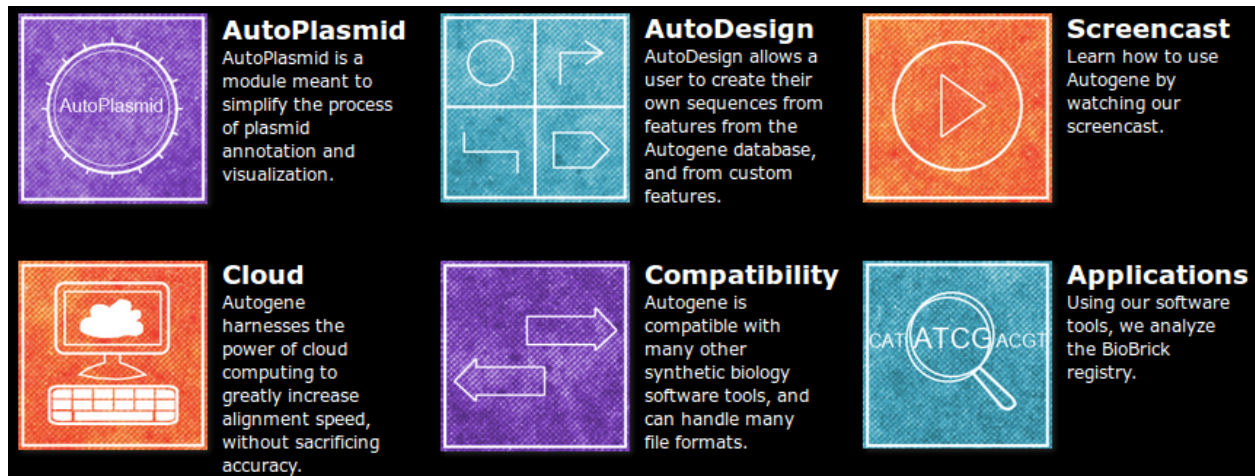

The AutoPlasmid program is the core of the project. It allows users to automatically annotate a DNA sequence by matching it against a database of 40,000 known plasmid features. Features can then be collected into a “private registry” and used in AutoDesign to create new plasmids.

It is clear why judges liked this project: It addresses an unmet and very practical need and could, potentially, be **very useful** to almost every experimental synthetic biologist, thus answering general rubric **aspect 5** (impact) and **9** (usefulness).

The programs are also very **user friendly (software aspect 5)** and the Wiki contains an easy step-by-step **user guide** with screenshots for all the important dialogs. Moreover, the team has used their software to check the annotations of some existing BioBricks and also analyzed the complete registry for the occurrence of pathogenic sequences. This application introduces **Policy & Practice** aspects (general **aspect 7**) and shows that the tool **works** (general **aspect 3**). This could also be interpreted as a rather successful **validation** of the software (earning perhaps 4 out of 5 points in **software aspect 2**), even though back in 2012, validation was not yet formally requested.

The team also did a good job at supporting existing **standards (software aspect 1)** by providing data import and export in four different formats (fasta, genbank, sbol, ApE). The parallelization of the Smith-Waterman alignment algorithm on an Autodesk cloud platform is certainly **not a trivial design (software aspect 3)** and is well documented on the Wiki. However, some critical questions (e.g. after the presentation) are in order: Why did they

choose this particular platform? Could things have been sped up with more simple text matching methods?

This leaves us with general **aspect 10** and **software aspect 4** concerning how well this software can be embedded and **extended or modified by other developers**. This was not a judging criterium in 2012. However, both software winners of 2012 are a good example why we need to emphasize these aspects more. The source code of both projects is available on GitHub. However, in both cases, there are hardly any comments in the source code and very few comments are registered, meaning the history of code development is lost. The John Hopkins team provides neither **documentation** nor **instructions for installation** from source. Now, two years after the Jamboree, the link for downloading the program binary is broken (see figure below). Thus, there is a big barrier to use or further develop this very promising tool.

Not Found

The requested URL /~eisinger/iGEM/Download.html was not found on this server.

Apache/2.2.15 (Scientific Linux) Server at ugrad.cs.jhu.edu Port 80

Meanwhile, the web server of the UT Tokyo team has also stopped working. Nevertheless, the team provides several useful README files. The README of their Biobrick_Search project, for example, contains a short description of each source file and sufficiently detailed step-by-step instructions for setting up a new copy of this web server.

 README

This information is sufficient to get other developers started and may already encourage some to dig in and improve this software. More can be done, though — possible examples include automatic source code documentation, unit testing or well described test cases. We would now also like to encourage teams to provide programming interfaces (such as library API, ReST, or even simple command-line calls) so that future teams can integrate this software into their own workflows.

Judges, of course, should use their common sense to balance all these demands, new and old, against the limited time and experience available to our brave teams, and never forget to congratulate and encourage them for their great work and enthusiasm.

New Tracks

New tracks in iGEM are how students and members of the community to participate in iGEM in areas that do not necessarily require submission of BioBricks. We can evaluate these teams differently, without the need to award them medals based on parts. We can be inclusive of all types of teams from different schools with the new track program. Software and Hardware, for example, have no requirement to make part to receive a medal.

New tracks are not split into undergraduate and overgraduate sections.

Art & Design

INTRODUCTION

At first glance, Art & Design seems to sit apart from tracks at iGEM that focus on scientific or technical challenges. But when you take a deeper look, you'll find that the best iGEM projects depend heavily on art and design. How so? Look at the past winners of the overall competition. You'll be hard-pressed to find teams that didn't: 1) convey their concepts with aesthetically compelling narratives; 2) elaborate novel ways that synthetic biology could reshape our made world, and by doing so 3) investigate our current individual, social, and technological conditions and 4) imagine how they could be different.

Good art and design performs all of these intrinsically, but there is one major caveat that differentiates this track from others. Most iGEM projects aim to use biology to solve clear, finite problems in the world. This is not always the case with art and design. Art and design teams can use synthetic biology to reveal **new** problems in the world and to sometimes reflexively reveal problems with the aspirations of synthetic biology itself. These projects ask the difficult question of "Why?" Why do we think the way we do? And why can't it be otherwise?

These projects are just as important as any because they ask us to rethink what we're doing.

Below, you'll find art and design case studies from previous iGEM projects. For simplicity's sake, we've categorized art and design under two different subheadings, with a third for the Applied Design Award. This should not mislead you into decoupling them.

People often distinguish design as focusing on a particular "application." A rubber eraser, for example, provides an elegant way to remove pencil marks. In contrast, they distinguish "art" as focusing on a particular set of "implications." The giant sculpture of an eraser outside the National Gallery in Washington, D.C., says something about the ubiquity of office rituals in our

lives (Claes Oldenburg and Coosje van Bruggen, 1999). In reality, the boundary between art and design is often not so clear cut.

DESIGN

Case 1: Art Center MDP 2014

The winner of the 2014 Art & Design Track, the Art Center MDP team created “Car Pools,” a project that imagined converting Los Angeles’s swimming pools into a network of open ponds for biofuel producing algae. The project was a critique of current metropolitan sustainability practices: Los Angeles has a water problem. It depends on water piped from Northern California yet has 43,000 swimming pools, many of which are rarely used. At the same time, the city is famously dependent on cars and fossil fuels for transportation.



The project addressed both dependencies in one fell swoop with the improbable but clever solution of turning swimming pools into open ponds for algal fuel production.

The power in this project is that it delved into the senselessness of the city's current geopolitics and asks why can't this be different? The seemingly absurd solution the team posed may in fact be more logical than the city's current situation. The team went even further by taking its premise seriously through a series of experiments and demonstrations that explore the feasibility of its idea. At the same time, juxtaposing LA's current situation with its speculative parallel, the project asked the viewers which scenario is more desirable, if either.

Car Pools asked how synthetic biology might be "domesticated" literally in our homes. The team imagined new social practices that might emerge from having your pool be full of algae. They experimented with "simulations" -- non-engineered algae in baby pools in their yards throughout the summer, where they learned how to care for this living creature in their backyards.

Case 2: University of Cambridge, 2009

One of the requirements to win a silver medal in the Art & Design track is submission of a video. Cambridge did a fabulous job in art and design with its "E. chromi" project back in 2009. Having won the grand prize that year, the team demonstrated the effectiveness of art and design at iGEM. The team worked on a series of inducible promoters and a rainbow of pigment genes for the production of bacterial biosensors that change color under different conditions.

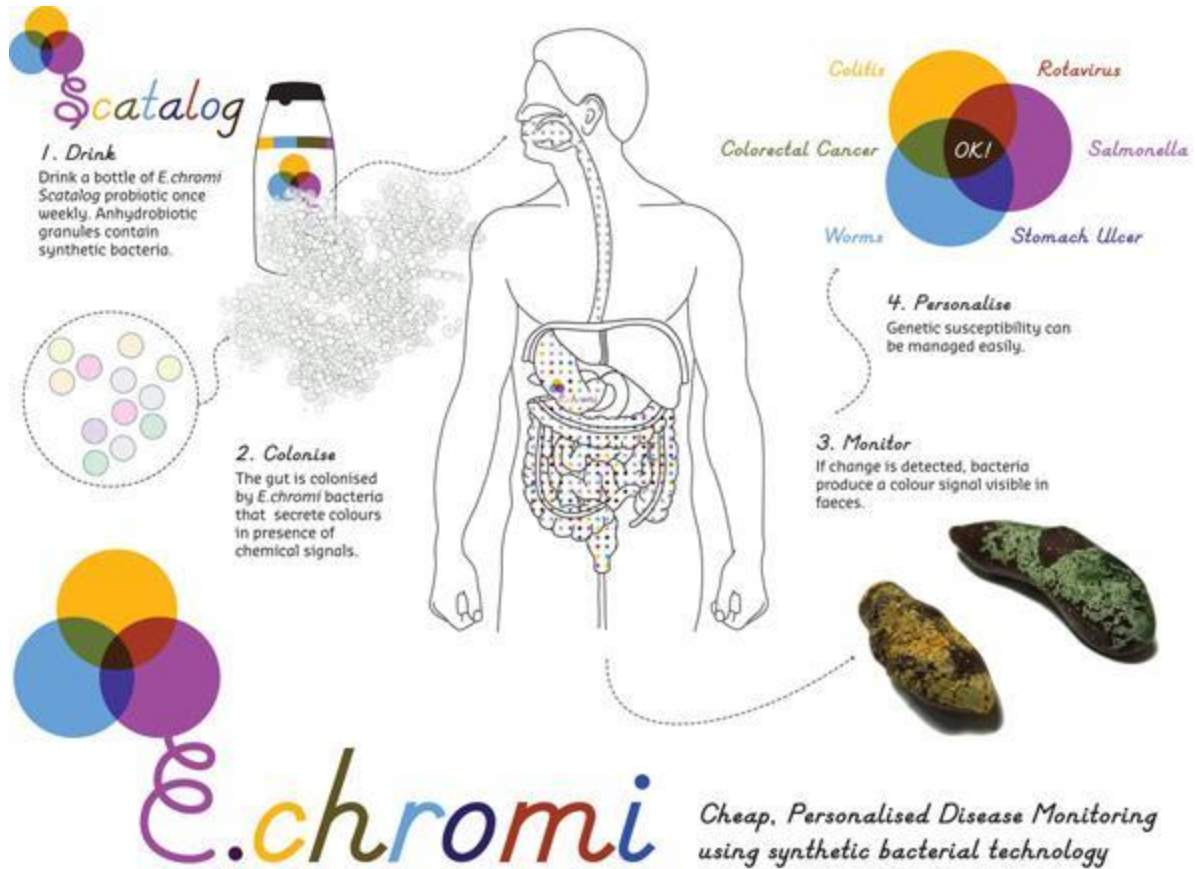

In conjunction with a team of artists and designers, the team brainstormed a number of future scenarios (many funny) that integrate color and synthetic biology. The affiliated artists, Daisy Ginsberg and James King, created a video highlighting the project. Student videos should strive to achieve similar results. Both fun and creative, the video demonstrated how the team had considered how their technology might be applied in the future—beyond just the obviously beneficial uses: <https://vimeo.com/19759432>

ART

Case 1: Art Science Bangalore 2009

Art Science Bangalore set out to biosynthesize the chemical geosmin in *E. coli*. Literally meaning “earth odor,” the microbial metabolite is responsible for the characteristic smell of moist soil or freshly plowed earth. Geosmin is produced by a number of soil bacteria and fungi.

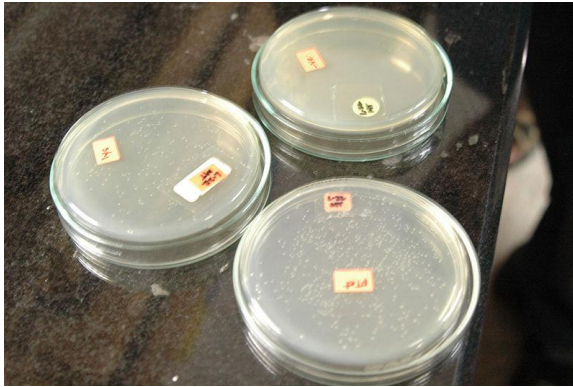

Chemical reactions involved in the synthesis of Geosmin

Scheme 1

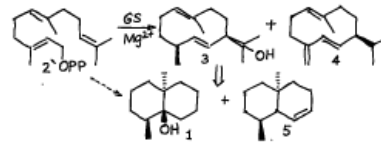

Scheme 2: mechanism of cyclization of FPP(2) to Germacadienol(3), Germacrene(4), Hydrocarbon(s) and Geosmin(1)



The team's goal was to recreate the smell of Indian earth after a heavy rainfall. The project was a poetic statement and a way of investigating the emotional and human sides of using synthetic biology. This is an area often disregarded by scientists seeking to purely advance the science, but is something vital to the future of synthetic biology if it is to someday become truly integrated within society.

This project was simple and subtle, allowing people to connect to biology on a nostalgic and personal level and providing an essential experience for people who interact with this work. We shouldn't only think about synthetic biology cognitively, but also sensually and emotionally.

Case 2: Paris Bettencourt 2014

Five years later, Paris Bettencourt 2014 took up where Bangalore left off, adding a number of scents to the iGEM registry such as popcorn and jasmine. Although not an art project per se, the project did investigate the meeting of synthetic biology and aesthetics. The team explored scents related to the human body and ways synthetic biologic might mitigate them by altering the human microbiome with bioengineered microbes.

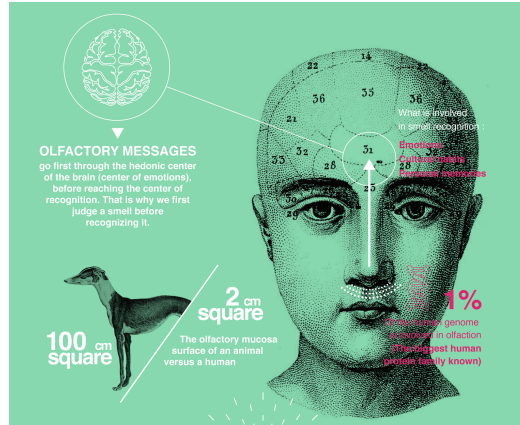

Through a participatory smell game that involved participants from around the world, the project took a deep dive into the sense of smells and the ways we react and relate to them emotionally. The team did excellent work in creating a narrative around its project while exploring how synthetic biology might reshape our sensorial experiences.

Community Labs

SF_Bay_Area_DIYbio

The {2014 SF Bay Area DIYbio team}[http://2014.igem.org/Team:SF_Bay_Area_DIYbio] chose to design yeast capable of making proteins found in milk, which, when combined with water and oil, can produce cheeses friendly to vegans or those with lactose intolerance or (some) milk allergies. This would reduce the need for dairy livestock and potentially reduce the greenhouse gas emissions per gram of casein produced by 40-90% (according to their estimation). They focused on the milk proteins:

- Bovine alpha casein S1
- Bovine alpha casein S2 (Kex + & Kex -)
- Bovine beta casein B
- Bovine kappa casein
- Human alpha casein S1
- Human beta casein
- Human kappa casein (Kex + & Kex -)
- Human Fam20C kinase (Kex + & Kex -)

which they argued would be sufficient for a cheese. They designed 11 of these parts, cloned 10 into *e. coli*, and as of the jamboree, were working to transform yeast - but had not yet successfully done so, or yet demonstrated expression and/or secretion of any of these proteins in either *e. coli* or yeast. One judge remarked: “The biology of casein is complex enough to satisfy any scientist. Why does it coagulate? How does expressing casein change yeast physiology. How can it be purified efficiently? What might affect the expression level? Why did you choose this genetic system?”

Impressively, they considered many aspects of scaleup, with a welcome comparison to current dairy techniques at a large scale.

Can we pull this off?



This would be the first attempt at making a bulk food from recombinant protein!

- Target yield: 2.5g protein/L
- Cost? “5g cheese for the price of 1L of expensive beer” (compare to \$250,000 for Mark Post’s *in vitro* hamburger)
- “Tasteable” amounts within months
- Actual product: 2016?



The project, though unfinished, with original and intriguing, and garnered significant interest. Their {launch video}[<https://youtu.be/eh6l7IXiEVM>] had 38,000+ hits as of May 2015, and their IndieGoGo campaign netted **\$37,369** US, including funds for a 50L bioreactor. Their crowdfunding and outreach successes were, frankly, extraordinary.

Press

We have been featured in over **100 articles** & a **Reddit AMA!**

It seems odd that anybody would have a reaction to this story other than "Cool, hope it works!" - **Slate**

Real vegan narwhal cheese? Well, I'm sure synthetic biology can get weirder – but this is a great start. I'm looking forward to tasting some. - **O'reilly Radar**

According to one judge: "This project is really capturing people's imagination and changing the way people think about our field."

The_Tech_Museum 2014

The {2014 Tech Museum team}[http://2014.igem.org/Team:The_Tech_Museum] aimed to provide patrons with an opportunity to collectively produce a palette of bacterial colors. Libraries of three-color plasmids under a variety of promoter strengths produce 729 unique combinations of three-color fluorescent protein intensities - in essence, 729 unique bacterial "pixels".

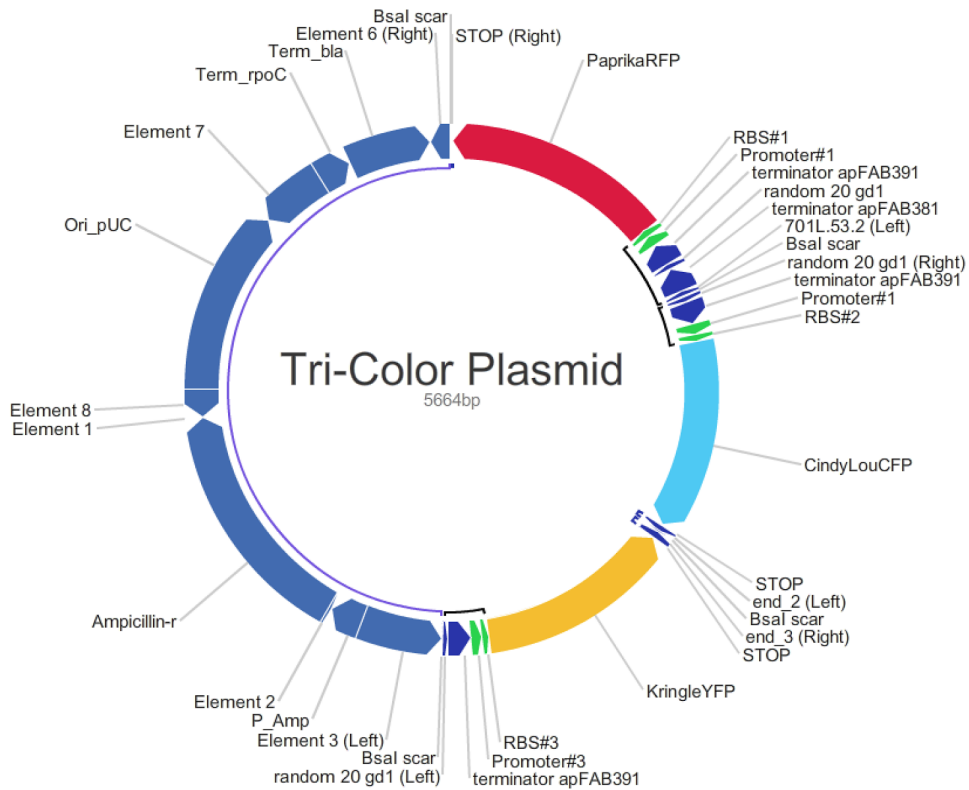

Patrons would choose a barcoded plate, photograph the colony colors, analyze the photo for new colors, and see their bacterial “pixels” added to the space of available colors via a projection. The iGEM team interacted with ~100 museum patrons, analyzed 2674 colonies on 61 dishes, and with them found a total of 324 unique colors.

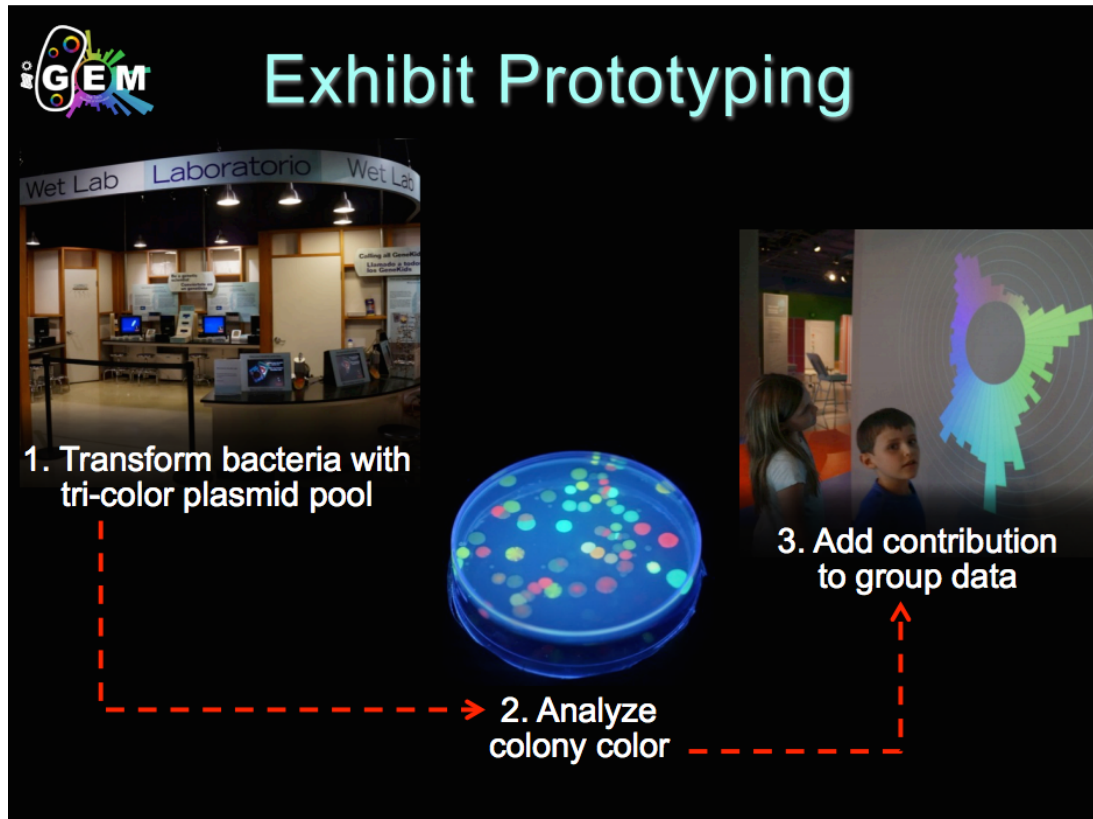

The team's {video}[<https://youtu.be/maO46uavuBQ>] describes their project in more detail.

Judges noted:

- “The visualisation software is really interesting and I can see how this would have really engaged a museum audience.”
- “I appreciate that the museum may not have been set up to do full molecular biology, but it would have been an even better project if staff had or someone else involved in the project had the opportunity to build some of the constructs rather than outsourcing it all the DNA2.0. It's also a real shame that no parts could be submitted to the registry as this is one of the primary judging criteria for iGEM.”

In general, the collaborative nature of the project - by participating, patrons could see their work expanding the space of available colors - was an able metaphor for the collaborative nature of science (though one judge would have liked to incorporate hypothesis generation & testing, if possible).

Hardware

Hardware Case Study 1: UC Davis 2014

UC Davis won the 2014 overgraduate division grand prize for their “OliView” project, which sought to achieve rapid and inexpensive quality control for olive oil. The motivation for the project was laid out clearly: over 65% of olive oil sold in the US is rancid, and there’s no fast and reliable way to ascertain the quality. To meet this need, the UC Davis team integrated protein engineering, hardware design, software, and human practices to create an inexpensive platform for measuring olive oil quality. While the hardware track did not exist in 2014, the OliView hardware component meets several of the rubric criteria for the 2015 hardware track.

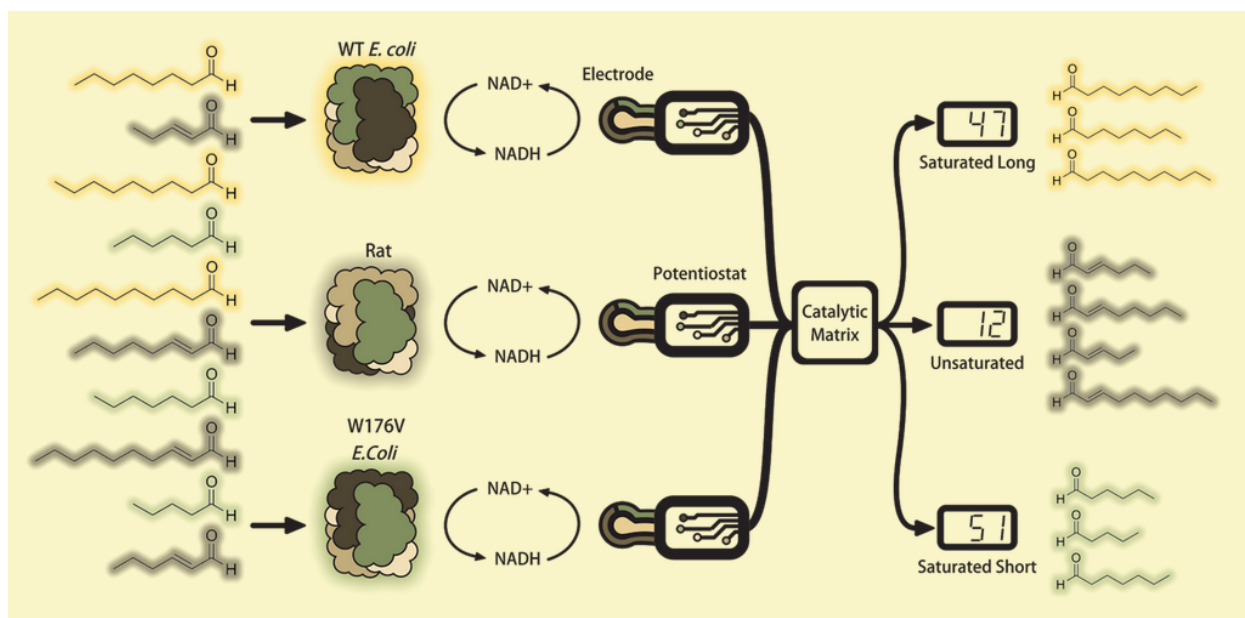

Fresh and rancid olive oils differ in their concentrations of unsaturated, medium saturated, and long saturated aldehydes. The team engineered several aldehyde dehydrogenase enzymes with varying aldehyde specificities, which generate NADH at different rates depending on the substrate present. In this way, when their engineered enzymes are added to olive oil extract, a unique electrochemical signal is produced dependent on the oil quality. To measure NADH production, the team built and tested a potentiostat—a device that keeps the voltage between two electrodes constant. When NADH is made, the potentiostat oxidizes it to NAD^+ at the electrode and generates measured current. Potentiostats are widely used to study redox chemistry, but the team found that existing commercial options didn’t suit their needs, and therefore they built their own. Key to the potentiostat’s function was the selection of appropriate electrodes. Considerations included sensitivity, selectivity, affordability, and portability. They ultimately decided upon an inexpensive pre-manufactured electrode.

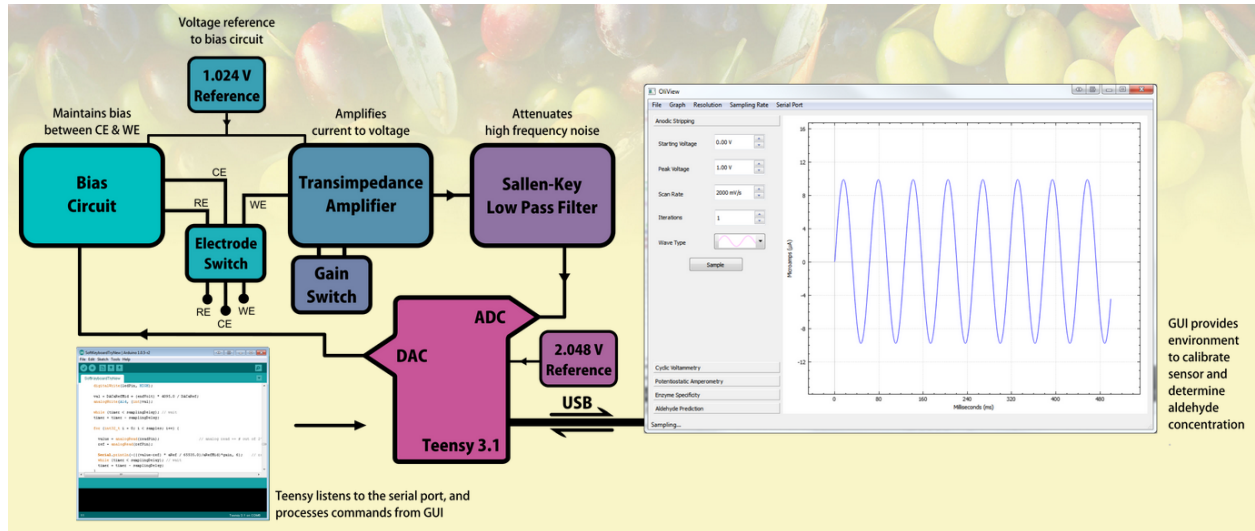

Schematics and PCB design files, a bill of materials, and software were each supplied on the team wiki (Silver medal criterion #2). The team was honest about their inspiration for their potentiostat, the CheapStat from UC Santa Barbara. The CheapStat was controlled using machine level code which the team decided would be unreasonable to learn given the project's time constraints. However, they ended up modeling their circuit on the CheapStat. The OliView potentiostat took shape over multiple rounds of revision, from a breadboard prototype, to a circuit board made using a milling machine on campus, to a printed circuit board (PCB) designed using CAD software and sent to a PCB manufacturing company. At each step, the improvements and lessons learned were concisely reported for each version. In addition, the team offered instructions on the wiki for building your own OliView. A video tutorial for using or building the device would have made an excellent addition (Silver medal criterion #1).



The OliView software component was also well documented, with descriptions of the microcontroller backend and different electrochemical operations available to the user, and explanations for the signal processing and statistics. Further, their software was made available at GitHub (Silver criterion #2). While several areas of the UC Davis team's project were exemplary, detailed attributions for the student's work needed better documentation (Bronze medal criterion #5).

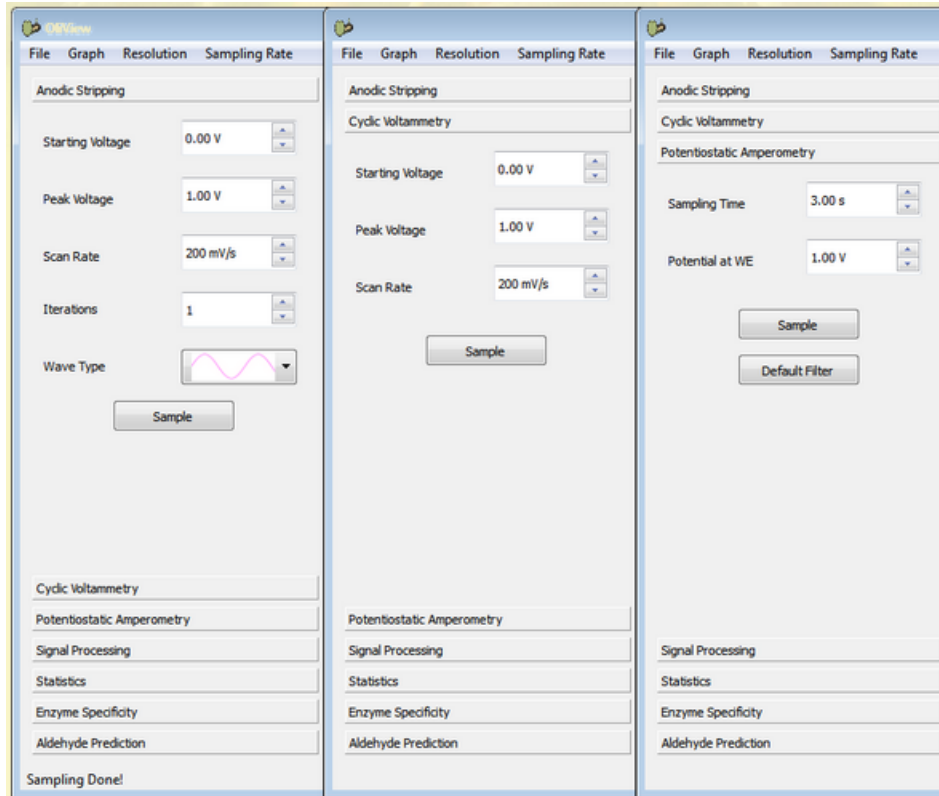

Finally, the UC Davis team integrated policy and practices into the motivation and design of their project (Gold medal criterion #1). They specifically sought to answer the question, “What sector(s) of the olive oil industry would benefit from the [OliView] device and be likely to utilize it in a commercial setting?” They met with olive oil producers, research scientists, and stakeholders in the olive oil industry and then summarized their findings in a report. They found that their low-cost biosensor could help maintain olive oil quality standards in the state of California, and could aid in the creation of a state seal for olive oil quality.

Overall, the UC Davis team’s execution of their project was outstanding in several aspects. The protein engineering, device implementation, and software design were all documented in clear, concise detail with schematics, code, and instructions at each step. Their project had a clear goal that was guided by discussions with many people in the olive oil sector. It seems possible that the OliView platform might make a real impact for olive oil quality.

Hardware Case study 2: Aachen 2014

The Aachen 2014 team won a gold medal and best Measurement Project at the 2014 Jamboree. Aachen 2014 exemplifies the spirit of iGEM’s hardware track goals with its combination of synthetic constructs and measurement hardware to create a novel biosensor capable of detecting pathogens.

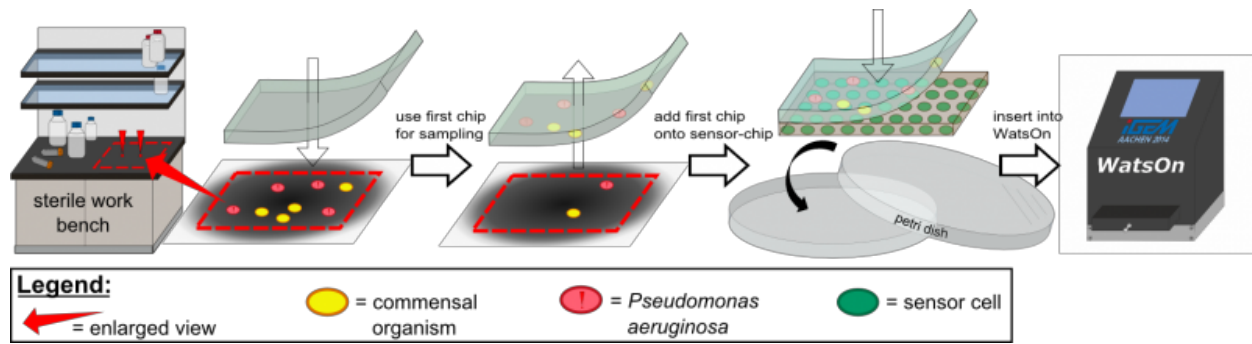

Fig1: Assay to detect *P. aeruginosa* using Cellock Holmes¹

This flow sheet shows the procedure to sample and detect *P. aeruginosa*: A sampling chip is briefly put onto the potentially contaminated surface, added onto one of our sensor chips and inserted into *WatsOn*.

The system works by collecting cells from a hard surface onto an agar pad. The agar pad is then transferred to a sensor chip that has been coated with *E. coli* that are sensitive to the quorum sensing molecules secreted by specific pathogens. A researcher then places the assembled chip and agar pad into their hardware measurement device named *WatsOn* (Fig 1).

Once the chip (LB agar mixed with sensor cells) has been loaded into the *WatsOn*, the chip is incubated allowing both the sensor cells and pathogens to grow. In the presence of pathogenic cells, a quorum will be reached and the sensor cells will fluoresce. The fluorescence can be detected by the fluorescence camera in *WatsOn* (Fig 2) and a classification algorithm can determine the presence of absence of pathogens.

¹ Images and captions by 2014 Aachen team.

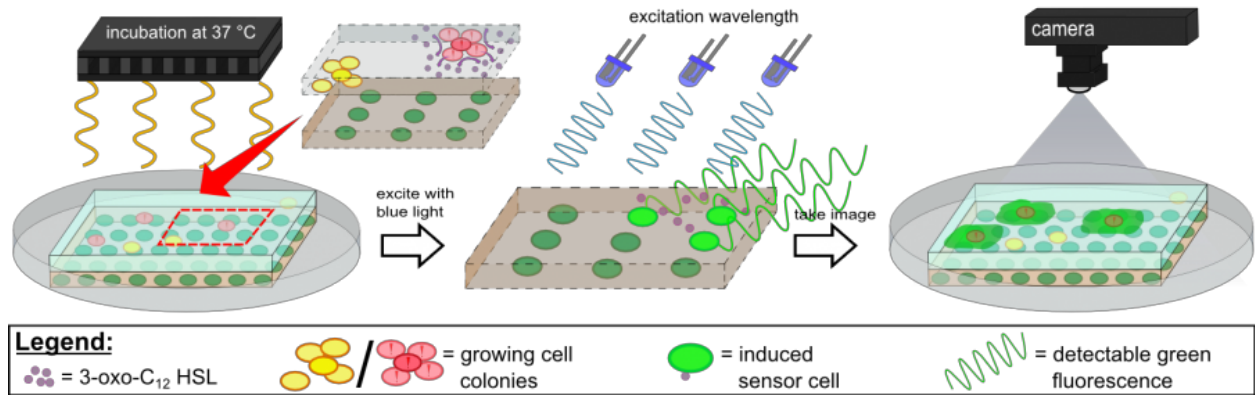

Fig2: Mode of action inside WatsOn²

Chips are incubated at 37°C to stimulate cell growth and then illuminated with blue light to excite fluorescence. A picture is taken and analyzed for fluorescence signals using the software *Measurarty*.

A basic judging criteria required for all metals is that the team demonstrates a working prototype. In Aachen 2014's case they did an excellent job. Aachen's website gives a complete characterization of WatsOn demonstrating its functionality detecting IPTG, 3-oxo-C₁₂-HSL, and living *Pseudomonas aeruginosa*, a human pathogen.

Reproducibility, and in the case of hardware, open design is an important aspect of every successful iGEM project. Aachen 2014's website has an excellent guide that contains all software, source code, a complete bill of materials, and assembly and operating instructions. Their website enables any researcher to assemble and operate their own instantiation of the hardware.

² Images and captions by 2014 Aachen team.

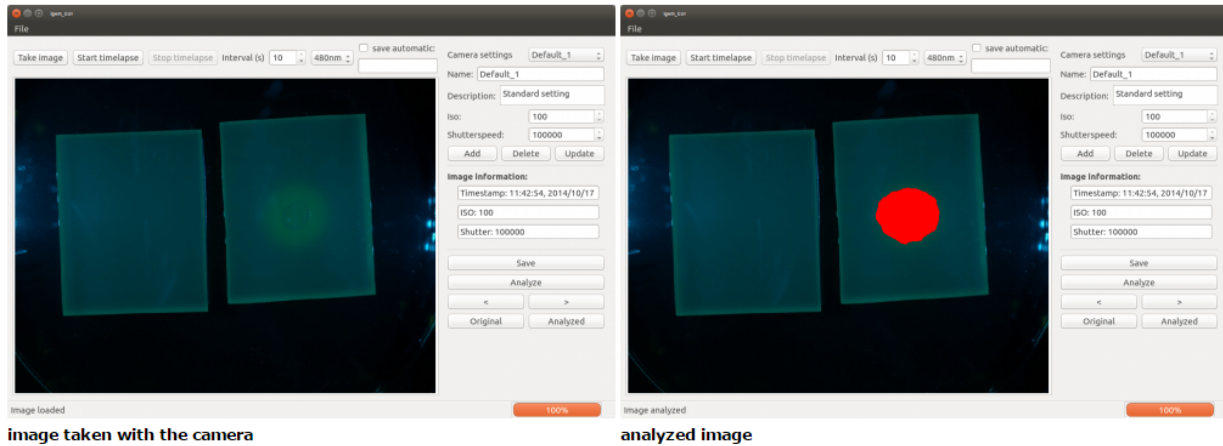

Fig3: An assay vs a control. Left: unprocessed image Right: the processed image showing detected fluorescence in red.³

Aachen 2014 addressed “beyond the bench” issues in multiple ways. They developed hardware and wetware to detect human pathogens, which addresses human health and safety concerns. In addition, they took biosafety into careful consideration during their design. Because their sensor includes active genetically modified bacteria, it is important to consider where the sensor chips containing this bacteria go. Rather than integrating the sensor bacteria into the test pad, Aachen decided to separate the test pad and assay chip, which can then be safely sandwiched back in the lab. This clever design decision reduces the chances of accidental release of the sensor bacteria.

The video demonstration judging criterion was not met by Aachen 2014 as it was introduced in 2015. Starting in 2015, a video tutorial showing the features and operation should be made available on every hardware team’s wiki to be considered for a silver medal.

³ Images by 2014 Aachen team.

High School

Although iGEM was founded as a collegiate competition, high school students have been participating in iGEM since 2011. From 2011-2014, the high school competition was a separate division with a separate schedule and Jamboree. Starting in 2015, however, high school teams will compete alongside collegiate teams as a New Track. Historically, high school teams have been judged using a separate rubric that reflected similar values and concepts to the traditional iGEM competition, but with more focus on **conceptual understanding** and **enthusiasm** and less focus on experimental success and part functionality. As a New Track, they will now be judged against the same rubric as the collegiate teams, but with medal requirements and track-specific aspects that emphasize the **educational experience** and **interaction with the iGEM community** instead of novel research achievements. For example, high school teams do not need to submit any parts to achieve a bronze medal; instead they must form a relationship with another iGEM team (either collaborative or mentor/mentee). Similarly, to achieve a silver medal, the teams must submit a part, but the part does not necessarily need to be novel, nor does there need to be significant experimental data on the Registry. Experimental characterization of the part on the Registry will instead help earn a gold medal. The track-specific aspects of the rubric also reflect the relaxed requirements.

When judging high school teams, please keep in mind that most high school teams must deal with additional factors such as a smaller budget, lower availability of laboratory facilities, and shorter working hours, not to mention the fact that the students probably haven't taken any college-level courses yet! As a result, *it can be considered a substantial achievement for a high school team to make a functioning part.*

This is not to say that high school teams are not able to make interesting and significant contributions to synbio! In fact, it can be difficult to distinguish between the best high school teams and many collegiate teams. To demonstrate this idea, let's look in detail at {Lethbridge Canada 2013} [http://2013hs.igem.org/Team:Lethbridge_Canada].

High School Case Study 1: Lethbridge 2013

Lethbridge Canada was the grand prize winner for the 2013 high school division competition. Their project aimed to produce a natural form of oxytocin and attach it to a carrier molecule to prevent the breakdown of oxytocin. Normally, oxytocin breaks down quite rapidly, making it difficult to use in the lab or as a therapeutic agent. This ambitious project was well received for two main reasons: thorough research and design of their two constructs and clear explanations of their methods and results.

The team designed two constructs. The first was to express the maximum amount of Oxytocin as possible, along with its carrier protein Neurophysin I. The team modified their

construct with both an *E. coli* signal sequence for extracellular export and a histidine tag for detection:

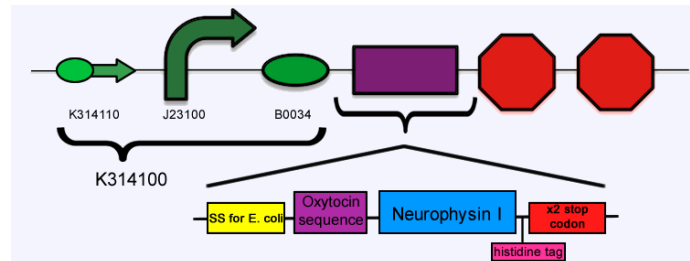

The team was able to completely clone this part, as shown by the {experimental data}[http://2013hs.igem.org/Team:Lethbridge_Canada/results] on their wiki. Even more impressive, the team was able to express the protein, as evidenced by a Slot Blot:

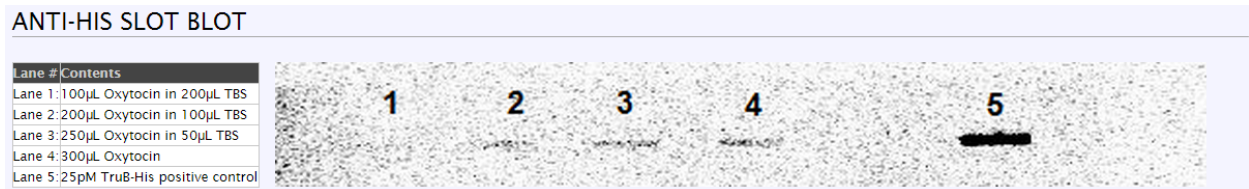

Lethbridge designed a second construct that would allow them to test many different promoters by combining them with mCherry. The idea of this construct was that it would give them a better idea of which promoter to use to maximize output of a secondary enzyme. Unfortunately, they did not have time to fully investigate the expression with different promoters. However, they used {mathematical modeling}[http://2013hs.igem.org/Team:Lethbridge_Canada/math] to help determine the correct promoter to use. Although the model is fairly basic, it is well documented and thoroughly explained on their wiki.

$$n_p = \begin{cases} \int_i^j \left(b_i 2^{\frac{t}{30\text{min}}} \right) \left[\left(\frac{4200\text{nt/min}}{l_{\text{gene}}} \right) \left(\frac{1}{2} \right)^{\frac{t}{h}} \right] \left(\frac{12 \cdot \text{RBS}}{7} \right) dt, & i \leq t \leq j \\ \int_j^k \left(b_i 2^{\frac{j}{30\text{min}}} \right) \left[\left(\frac{4200\text{nt/min}}{l_{\text{gene}}} \right) \left(\frac{1}{2} \right)^{\frac{t}{h}} \right] \left(\frac{12 \cdot \text{RBS}}{7} \right) dt, & j \leq t \end{cases}$$

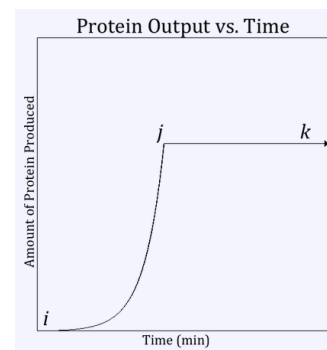

Furthermore, the team made extensive connections between their project and their community through a variety of human practices activities, including interviews with local

health professionals, discussions with their school boards, and surveys of their parents' attitudes towards iGEM and their participation in it.

In conclusion, this project was successful for multiple reasons:

1. The team used thorough (and attributed) background research to design a novel, elegant system to produce biological oxytocin.
2. They successfully cloned and expressed one of their constructs, and they posted their sequences and designs to the Registry.
3. They performed mathematical modeling to describe how their system would function *in vitro*.
4. Their wiki, presentation, and poster were simple, clear, and to the point.
5. They connected their project to their community through multiple human practices projects.

In short, Lethbridge Canada 2013 completed all of the tasks normally associated with a successful parts-based iGEM project. Although the level of detail and complexity of the project are somewhat lower than most collegiate projects, the team was able to succeed in a number of difficult challenges (e.g., making a working part, using modeling in lieu of experimental work) and effectively communicate their project to a broad audience. These qualities made Lethbridge Canada a winning high school team.

Another outstanding high school team was {CSIA-SouthKorea} [<http://2014hs.igem.org/Team:CSIA-SouthKorea>], the grand prize winner for the high school division in 2014. Their project revolved around the production of a urease enzyme which would precipitate calcium carbonate, forming a biocement which could be used to stop desertification.

CSIA-SouthKorea was successful for two main reasons: convincing part characterization and strong human practices. After completing cloning of their urease enzyme part, they demonstrated its strong functionality with multiple methods to detect urease function, all with good control groups: a urease assay, biocementation with crude extracts, and biocementation with whole cells on a special agar plate:

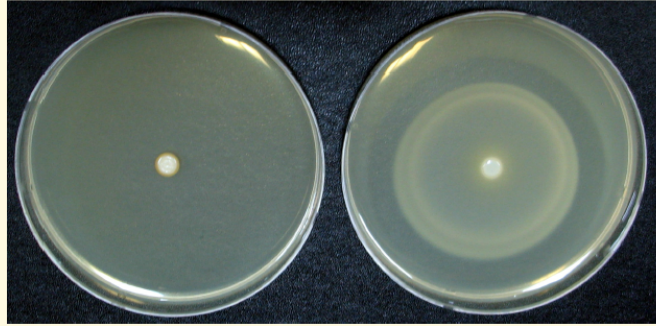
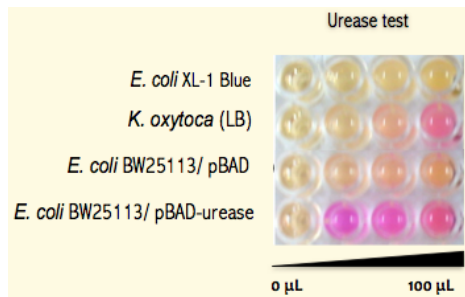

Fig. 6. Biocementation test with whole cells on Calcite precipitation agar (CPA), 5 days later *E. coli* BW25113/ pBAD showed no biocementation activity; *E. coli* **BW25113/ pBAD-urease showed biocementation activity.**

In addition to making a functioning part, the team also thought about how their part could be used for other applications, showing that the team thought about their project from a broader perspective. Finally, the team participated in a number of human practices activities, including running an essay contest, holding a workshop for students and a conference for the public, cooperation with a phone app that helps prevent desertification, and donating to various desertification projects. In combination with a clear and enjoyable presentation, these aspects demonstrated that CSIA-SouthKorea was a strong team that showed enthusiasm for their project and a good fundamental understanding of the science and implications of it.

Measurement



In synthetic biology, measurement is a critical challenge that is receiving an increasing amount of attention each year. For example, one of the long-standing goals of both iGEM and synthetic biology at large, is to characterize biological parts, so that they can be more easily used for designing new systems. The aim of the iGEM Measurement Track is to get students informed and excited about these problems, and to highlight the successes that teams are able to achieve in the area of measurement. The Measurement Track also aims to find out what measurement assays teams have available and to lay groundwork for future more complex measurement activities in iGEM.

Measurement Track - Summary of 2014

As the largest new track in 2014, we believe the Measurement Track was a great success last year. Teams from the Measurement Track won five prizes during the Awards Ceremony, which only helped to highlight the strength of the new track. Prizes were awarded to Aachen, Sumbawagen, and DTU-Denmark, and 5 teams won Gold, 3 won Silver, and 2 won Bronze medals. Projects ranged from measuring RFP with a cell phone camera to building functional hardware to measure optical density and fluorescence. Given the exciting projects and broad interpretation of “measurement” that the teams encompassed, we are excited to see what happens in 2015 and beyond for this track.

InterLab Study 2014

We also initiated the InterLab study in 2014 as members of the Measurement Track Committee. This study was open to all teams in the competition and, for 2014, we asked teams to measure fluorescence across three devices expressing green fluorescent protein (GFP) with varying ribosomal binding sites and vector backbones. Measurement directions were intentionally kept vague to see how teams would rise to the challenge and we were impressed with consistency seen in the data sent in by 37 teams.

Case Study #1: Aachen 2014 - winner of the Measurement Track

The 2014 Aachen project was titled *Cellock Holmes* and aimed to detect bacteria on solid surfaces. As a part of this project, Team Aachen designed and built *WatsOn*, a proof-of-concept do-it-yourself 2D biosensing system (overview schematic shown below). The team used agar chips inoculated with sensing bacteria to determine if their system was capable of detecting another bacteria on a solid surface. The *WatsOn* system was built using a Raspberry Pi and an Arduino board, which controlled the excitation of LED lights and a Peltier heater for incubation. The team also implemented the *WatsOn* software complete with a graphical user interface, backend scripts running on the Raspberry Pi, and the code needed to run the Arduino board. To complete this package, the team also created *Measurarty*, an image analysis software component used to interpret the images generated when the inoculated agar was placed inside *WatsOn*, where it was incubated and exposed to specific LED wavelengths. Combined, *WatsOn* functions as expected (described below) and can be built by end users for just over \$300 USD, thus allowing researchers with limited funds to easily measure and quantify fluorescence. These areas of the project clearly address *aspects 1, 2, 3, 4, 5, and 6*.

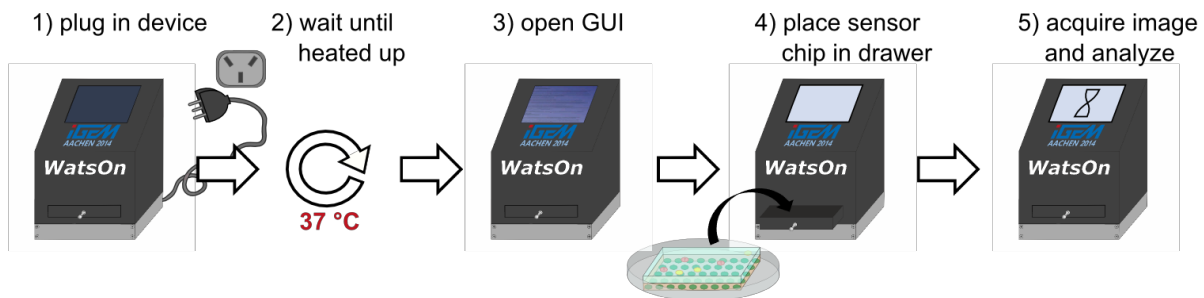

The hardware aspect of the Aachen project was only one part of their work. In order to detect the presence of bacteria with *WatsOn*, they needed to create a genetic device that would generate fluorescence. The team chose *Pseudomonas aeruginosa* as their target organism due to the quorum sensing systems found naturally in *P. aeruginosa*. The team then engineered sensor *E. coli* cells, termed *Cellocks*, to detect *P. aeruginosa*'s native autoinducer (homoserine lactone, or HSL) and then output a fluorescent signal when HSL was detected.

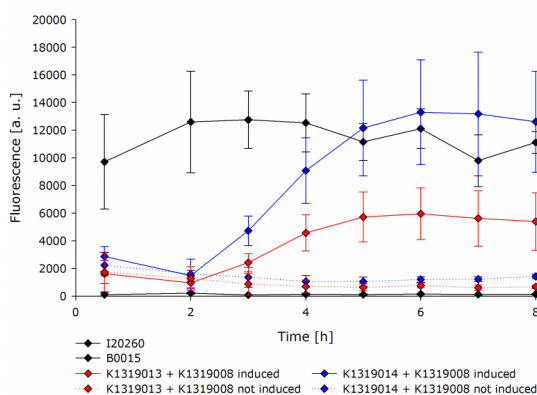

They also took the measurement of fluorescence seriously when designing the genetic devices for testing in the *WatsOn* system. They designed a system that would bind with HSL and output GFP, which they could then measure using *WatsOn*. Prior to testing these cells on *WatsOn*, Aachen measured the fluorescence using a plate reader to

make sure their devices produced GFP in the presence of HSL (shown left - *aspects 3 and 4*). This data was also used to build and refine a model of their system (shown below).

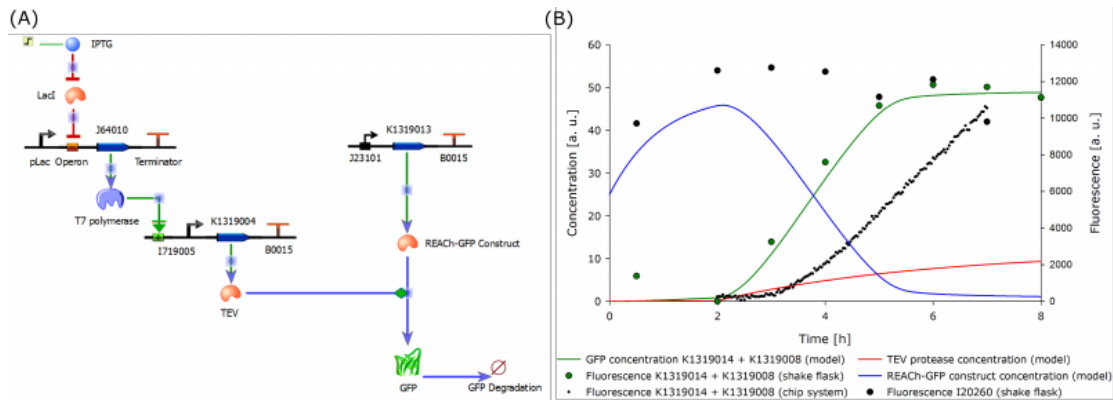

Once determined to work in liquid culture, the team tested *WatsOn* using agar slabs seeded with their sensing cells. When *P. aeruginosa* was present, GFP was produced and clearly seen using *WatsOn* with and without the image analysis tool, *Measurarty* (left and right below, respectively - *aspects 3 and 4*).

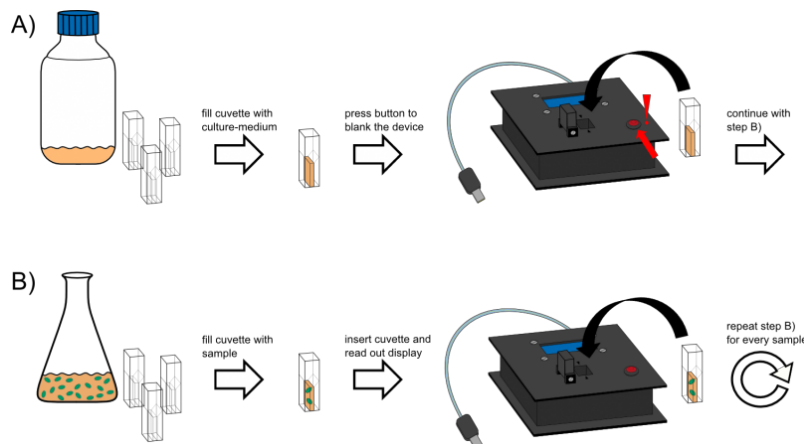
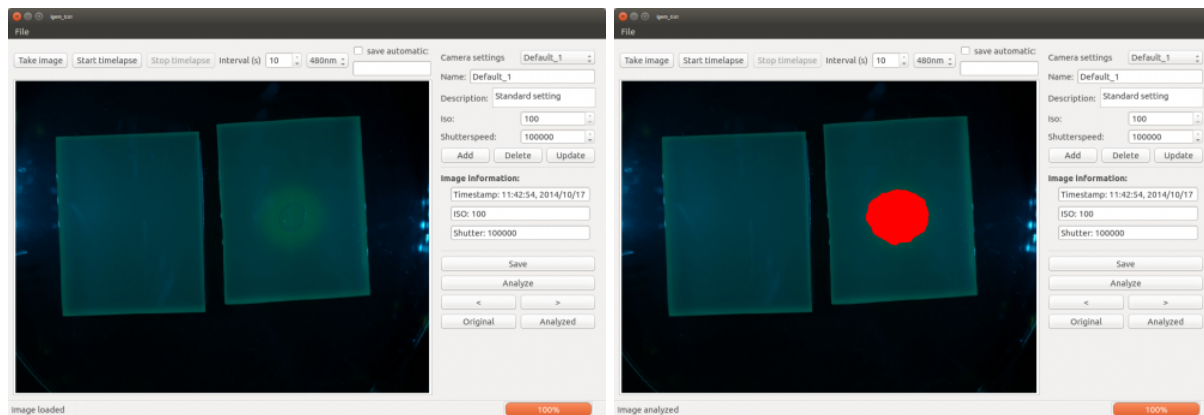

While *Cellocks Holmes* was their main project, Aachen also developed a small OD/F Device for users to build themselves that can measure both optical density and fluorescence. They were successful in designing, building, and testing a

handheld OD/F Device for the cost of \$60 USD (*aspects 3, 5, and 6*).

Aachen also explored policy and practices throughout their project. In particular, they took the safety concerns into account during the design of their system, attended a MakerFaire to exhibit their systems, and took the time to reach out and educate the public about synthetic biology (*aspect 7*).



Aachen's project was an impressively complete iGEM project where they executed a well engineered system, both biologically with bacteria and physically with hardware, and took into account the modeling of the biology as well as the safety issues surrounding their work. As a Measurement Track team, Aachen also participated in the InterLab study. In recognition of these achievements, Aachen won Best Measurement Project in 2014. They were also awarded Best Supporting Software, a Safety Commendation, and a Gold medal.

Case Study #2: Sumbawagen 2014 - winner of the inaugural Chairman's Prize

The Sumbawagen team aimed to measure red fluorescent protein (RFP) using an Android-based mobile phone, which would increase the ease of measuring RFP for any researcher. They focused on a mobile phone platform since they did not have access to more "high tech" equipment, such as spectrometers, plate readers, or flow cytometers. They decided to develop an assay that they could read using a mobile phone camera since it's a piece of technology that is nearly ubiquitous and thus available for most synthetic biology researchers. Their enthusiasm for synthetic biology despite their hardships (they had to build their own shaker, for example) and creativity in measuring RFP won them the first Chairman's Prize at the 2014 Giant Jamboree.

Their project focused on measuring glucose levels in honey, which is a major product from their home island of Sumbawa. They designed and tested a genetic construct that would turn RFP off in the presence of glucose through catabolite repression of the pLac promoter. They were able to successfully measure RFP and thus glucose levels using their mobile phones, but not green fluorescent protein (GFP) as shown in their Interlab Study data. It should also be noted that this team participated in the Interlab study despite their inability

to reliably measure GFP and provided us with a very impressive negative results write-up (<http://2014.igem.org/Team:Sumbawagen/interlabstudy/results>).

Highlight: Sumbawagen and Aachen Collaboration



One of the best results that came from the Measurement Track this year was the surprising collaboration that was set up following the Awards Ceremony between Teams Sumbawagen and Aachen. In exchange for some of their native honey, Sumbawagen is going to receive one of Aachen's pieces of hardware that the German team designed and built for this year's competition. This will allow the Sumbawagen

students to measure optical density and fluorescence, which was impossible for them this year given their long distance from any such equipment (over 1000 km from their campus!). This type of collaboration is what makes iGEM great and we were humbled to have witnessed this exchange.

Case Study 3: DTU-Denmark - winner of the Overgraduate Best Parts Collection

DTU-Denmark's project centered on measuring promoter function through the measurement of RNA production through the use of the Spinach aptamer. The Spinach aptamer binds to a fluorophore when the RNA sequence folds properly, which then activates the fluorophore and thus gives off fluorescence that can be easily measured using GFP filters. This method is particularly useful because it removes translation efficiency from the measurement of promoter function, which can be a source of variation in promoter measurements.

In their project, DTU modified the Spinach aptamer to remove the illegal SpeI sites in order to generate BioBrick-friendly versions of the aptamer (shown below).

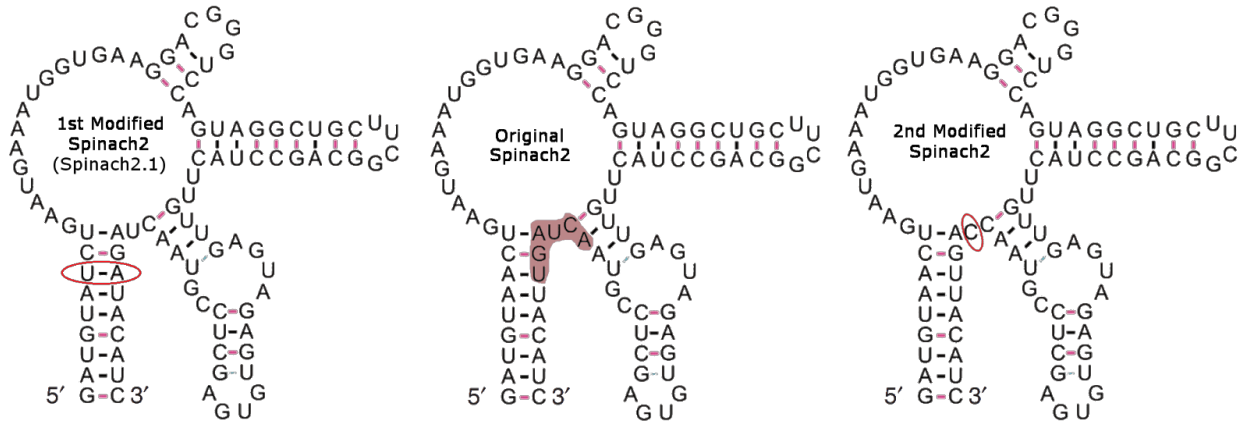

They then tested the Spinach 2.1 construct using the Anderson library of constitutive promoters and measured the fluorescence through GFP filters. They highlighted five Anderson promoters based upon their expected variation of expression (gray bars in graph below as obtained from the Registry). The measured Spinach 2.1 fluorescence correlated nicely with the expected function (orange bars).

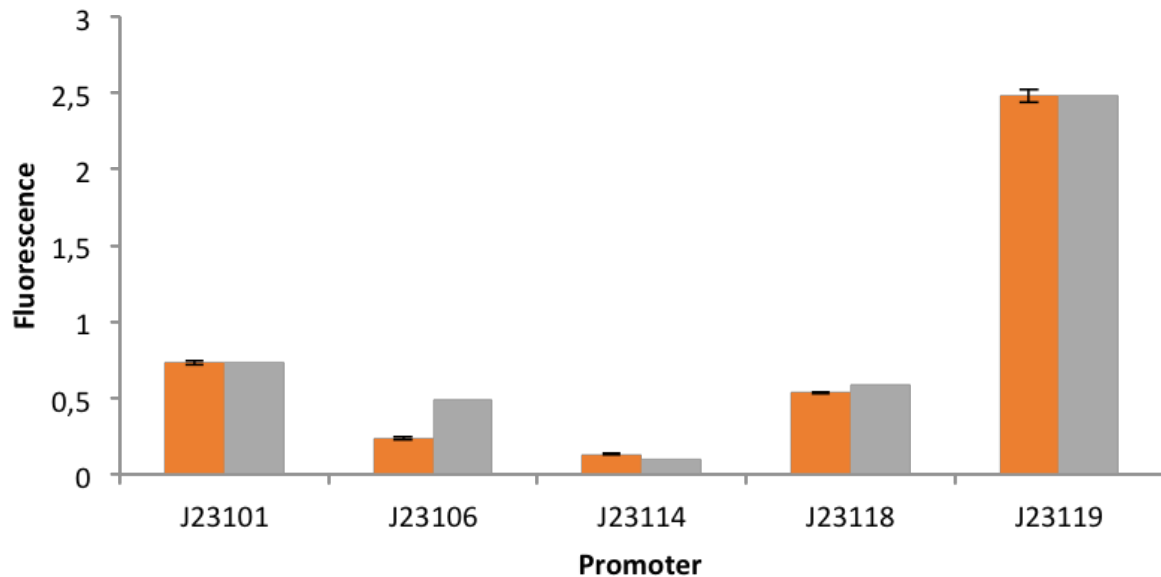

They also created an *in vitro* Spinach 2.1 standard that can be used to correlate fluorescence to RNA concentration. This standard will allow future teams to utilize these Spinach aptamers and compare data with other assays. They also used the slope from their standard curve to help estimate the PoPS (RNA Polymerase per Second) for each promoter with the Spinach 2.1 molecule.

Strain	Fluorescence	[Spinach:DFHBI]/ μM	[Spinach]/ μM	CFU/L	Spinach/cell	Production rate	PoPS
101	4.45	3.67	6.11	6.3E+12	584357	248.68	1.24
106	2.21	1.43	2.38	1E+13	140710	59.88	0.30
114	1.59	0.81	1.35	1.3E+13	61741	26.27	0.13
118	3.81	3.03	5.05	7.4E+12	411232	175.00	0.88
119	34.85	34.07	56.78	1.4E+13	2424887	1031.92	5.16

Software

Judging the Software Track

The iGEM software track judging experience is a little different from that of the wetlab tracks. This is because you are judging a software tool, a user experience, a scientific project, a mountain of data, and any associated documentation about how the tool was built - all at the same time.

The iGEM software committee values projects that produce, among other things:

- New scientific methods for synbio
- New visual systems and methods of representing biological data
- New methods of organising, managing, or accessing biological data
- New methods of exchanging and updating data relevant to experiments or organisms
- Innovative approaches to implementing any of the above with novel code
- A team that is experienced in both software development and synthetic biology

Thanks to using software repositories like Github, judges are free to browse every single aspect of a software team's project. As such, judging this track can be a very involved process, and you should be prepared to interrogate the code and documentation of each team as much as possible. Ideally, judges should have opinions on code quality before seeing the team's presentation. You should also attend poster presentations during the Jamboree, as this will give you good opportunity to ask more questions and learn who did what.

Ofentimes, obtaining data to use on a team's project can be difficult. You should expect to be able to use the software tool yourself, or at the very least be convinced that the tool is usable with a live demo.

How to judge small vs big teams

In the past, software track teams have won gold medals for creating something "big, useful, and valuable" or demonstrating a tool that is "small, innovative and validated".

The committee emphasizes that judges should reward innovative approaches to tractable problems in synthetic biology, and you should prioritise this over teams that have favoured making heavy use of shiny javascript libraries over and above "utility in the field". To put it another way, some teams are much bigger than others, and may have more resources and experience to draw upon to make something pretty. Keep an eye out to make sure all team members have learned about the underlying biology. Furthermore, you should judge each team on its own merit - some teams are very big and have done iGEM software for a few years whilst others are smaller, especially if it's their first year. You should be aware that this has been an issue for judges in the past. The committee has provided instructions below for dealing with such issues.

Libraries and innovation

Different uses of libraries can be rewarded in different ways. Judges should reward teams that write their own libraries from scratch, as these can be reused by the community in years to come. This is very much in the spirit of iGEM. Teams can also make valuable contributions to the community when they reuse or alter existing libraries in useful, innovative ways.

At all times, judges should question and think about where the innovation in a project was - did the team innovate on the fundamental biology whilst using libraries, or did they use a library and change a few parameters to make an output look slightly different? In general, we would like to reward when teams appropriately build on previous work, adding their own code and citing the previous work appropriately.

Poster Sessions

Poster sessions are a fantastic time to interview each member of a team and understand who did what. Speak candidly with all members of the team if you can. It might be that only one person wrote the code, which would not really be in the spirit of the competition - all team members should be improving in some way, and you must be convinced of this if you are to comfortably award a gold medal.

Poster sessions are a great way to explore the project and team away from the rehearsed environment of a presentation, and you will be able to dig deep on a lot of the questions that you'll have after reviewing code and projects.

Potential Questions to Ask

- What part of the code did you write?
- Where did you use libraries?
- How do you know this is innovative/valuable?
- Did you do a prior art study in the field?
- Who did what in this project?
- How well did you work together and how?
- Please explain the project to us?

Questioning Teams

Dig in deep and see if weaker members truly understand the project. You may experience some communication issues with non-native english speaking students, but you should be able to tell between communication problems and a lack of knowledge of the project. Remember to explain to team members that they can relax during this process! A lot of students will be frightened of the wrath of a judge - it's your job to make sure they relax and do the best they can.

Changes from Previous Years - Getting to Grips With Biology

In the past, the committee advised judges to award gold medals only to teams who had experimentally validated their tool in the lab as a mechanism of ensuring the tool worked and the team understood the underlying biology. This was changed in 2015, as the committee found that only some teams were able to carry out this instruction. Many team members come from a pure software background and so teams often lacked the ability and/or the equipment. A gold medal will be determined based on which two criteria the teams meet and whether the judges are convinced.

The requirement was relaxed in 2015 and judges should look for teams that collaborated to solve wetlab problems with software solutions. iGEM has adopted this rule as wetlab teams are very likely to have a problem that can be solved with good software, and so software track teams should attempt to provide additional solutions to them where possible. This will encourage software teams to hone their abilities in executing user experience testing, a core software development skill, as well as ensuring that a biology

team is directing the software team to build useful tools. Any experimental verification that comes out of the collaboration is a bonus.

Judging Use Cases from 2014

The following two sections highlight software track teams from 2015. UTSC-Software, a Chinese team, demonstrated their Biopano tool and won a Gold medal. Michigan-Software, a US team, demonstrated their ProtoCat tool and won silver. The descriptions of each team below detail their performances during their presentations as well as the strength of their software tools, wikis, and documentation, all taken together to give an overall outcome that can inform your judgment of 2015 teams.

UTSC-Software - BioPano

BioPano is a software platform built to visualize the relationships between different DNA parts and solve the problem of unexpected host-biobrick interactions. It was built by UTSC-Software in 2014.

The team introduced Biopano with a clear explanation that made use of a defined problem in experimental biology, as well as clear user need in the lab. They were somewhat heavy on the technicalities of the software, but not in a confusing way. Their project was written in good English, and the motivation for creating it, as well as the need for the tool, was understandable by a non-technical individual.

USTC-Software demonstrated the relevance of their tool for Synthetic Biology based on standard parts. They built a “biobrick assistant” that allowed the user to directly enter precise numbers of Standard Parts, and obtain parts types in “BioBrick Assistant Windows”. The team made use of well-known pre-existing algorithms, and users could use the BLAST function within the BioBrick [Assistant](#). The team demonstrated utility for synthetic biologists by proving that Biopano could, to some extent, predict the impact of a molecule on the host, and it could proactively warn against certain combinations of parts. The implied use of extensive rulesets was reflected in their code. Nonetheless, there was concern by the judges that BLAST was not necessarily a relevant tool to deploy in these situations - and that the team might have put it in there simply to check a box. Judges should be on the lookout for this kind of behaviour.

UTSC-Software prepared a comprehensive and well-designed user guide and included it on their wiki [here](#). The guide provides details on all functions afforded to the user. In addition, other software developers are able to build on their work thanks to their detailed API documentation, [here](#), which was automatically built using TOC (teams should generally attempt to use automated documentation tools where possible).

Teams are encouraged to follow best practises in software development so that other developers can modify, use and reuse their code, with more than one realistic test case. Examples of best practices are: automated unit testing and documentation of test coverage, bug tracking facilities, documentation of releases, and changes between releases. UTSC-Software implemented automated deployment capabilities so that code pushed to their production branch would be deployed to all users within ten seconds, and also worked to employ automated testing on that code, to prevent bugs from surfacing for users. In the case that bugs did make it through, users of BioPano could contact UTSC-software, providing them with in-application links to YouTrack, a popular tool for bug tracking and feedback coordination. UTSC-software also made their GitHub and GitLab account available to their users. Finally, their server applied automated unit testing to check the legitimacy and function of the code uploaded by a user.

UTSC-Software provided a convincing and non-trivial validation of their tests - something which judges should always be looking out for - by demonstrating an analysis of the length of time their heuristic algorithm would take to find more than one path connected to two nodes in a given network. They did this using a pre-existing python library. Further, they made use of the SBOL format as users could explore data as an SBOL file, keeping in line with this requirement, and also linked nodes with experimental data gathered by other groups.

BioPano produced an incredible project that left all judges wowed in most cases. It was complete, polished, well-thought out, documented, reusable, and felt to be of generally professional quality. The tool could comfortably be used by a biologist wishing to explore the utility of Biobricks in certain hosts. In fact, it's quite hard to see why this wouldn't be an essential tool. The wiki was pretty, the demo video was useful, and the team met all specified requirements.

Michigan Software - ProtoCat

ProtoCat is a protocol database project developed by Michigan Software in 2014. Michigan introduced ProtoCat as a software tool that could potentially address a variety of problems. Based on a survey of scientific students and professionals, they decided to focus on the construction of a protocol database.

Overall, the project was successful in generating a functional database of protocols, and the team raised awareness of their tool amongst scientists. They made use of existing software development frameworks, and created a tool that was apparently easy for other developers to extend, and for users to implement into synthetic biology workflows. The code was available in a well-documented form on GitHub, with clear instructions as to how to download, install, and develop it for one's own use.

Michigan-Software built a project that had well-studied use cases that could not be argued with according to the judging criteria. It could fit into workflows, it was simple and could be used, and was agnostic and fairly flexible, and built as a result of some outreach to the synbio community.

The judge's concerns centered upon how innovative the project was when compared to OpenWetWare or other available wiki tools. ProtoCat had no biology-specific functionality or support for synbio standards & platforms, so the case for using it vs. the use of existing tools was unclear.

The judges felt that ProtoCat would have benefited from better documentation and testing; more consideration of the user experience; and, particularly, by validation with experimental work (which was a Gold medal requirement at the time).

Michigan software received a silver medal.

Thoughts on BioPano VS Michigan Software

UTSC had two dozen team members and pulled off a very impressive and expansive project that won gold, whereas Michigan had around 5 members, and worked on a simple project that was not as impressive, but still received a silver medal. In general, the scope of the projects was largely ignored by the judges, and they

instead judged the teams based on the level to which they had completed their objectives, as well as the level of innovation they had demonstrated in delivering those objectives.

Questions to consider when judging software teams

When judging software teams, consider projects on the merit of their ideas, and the merit of their software. When in doubt, ask the following questions and arrive at a decision:

- What was the overall quality of the tool?
- Has the team built a software tool that people would find useful?
- Is the software well designed for a synthetic biologist?
- Can I understand the documentation?
- Would a non-technical person understand the software?
- Would a software developer want to use this as a platform for more work?

Remember - be positive with the teams! They take what you say very seriously, and you should give them your support and experience however you can.

Acknowledgements

We are excited to be able to present this document to the judges this year. However, it would not have been possible without the help of many of our contributors. In particular, we would like to thank the efforts of Martha Eborall, King Chow, Roman Jerala, Raik Grünberg, Ed Perello, Gil Alterovitz, Jenhan Tao, Evan Appleton, Emma Frow, Megan Palmer, Dan Grushkin, Christina Agapakis, Will Canine, Dave Kong, Janet Standeven, Jake Beal, Traci Haddock, Todd Kuiken and Jason Kelly.